

Nesting. One action in action.

HC HOMAG

Our Gantry-Processing Center
CENTATEQ N-300

YOUR SOLUTION

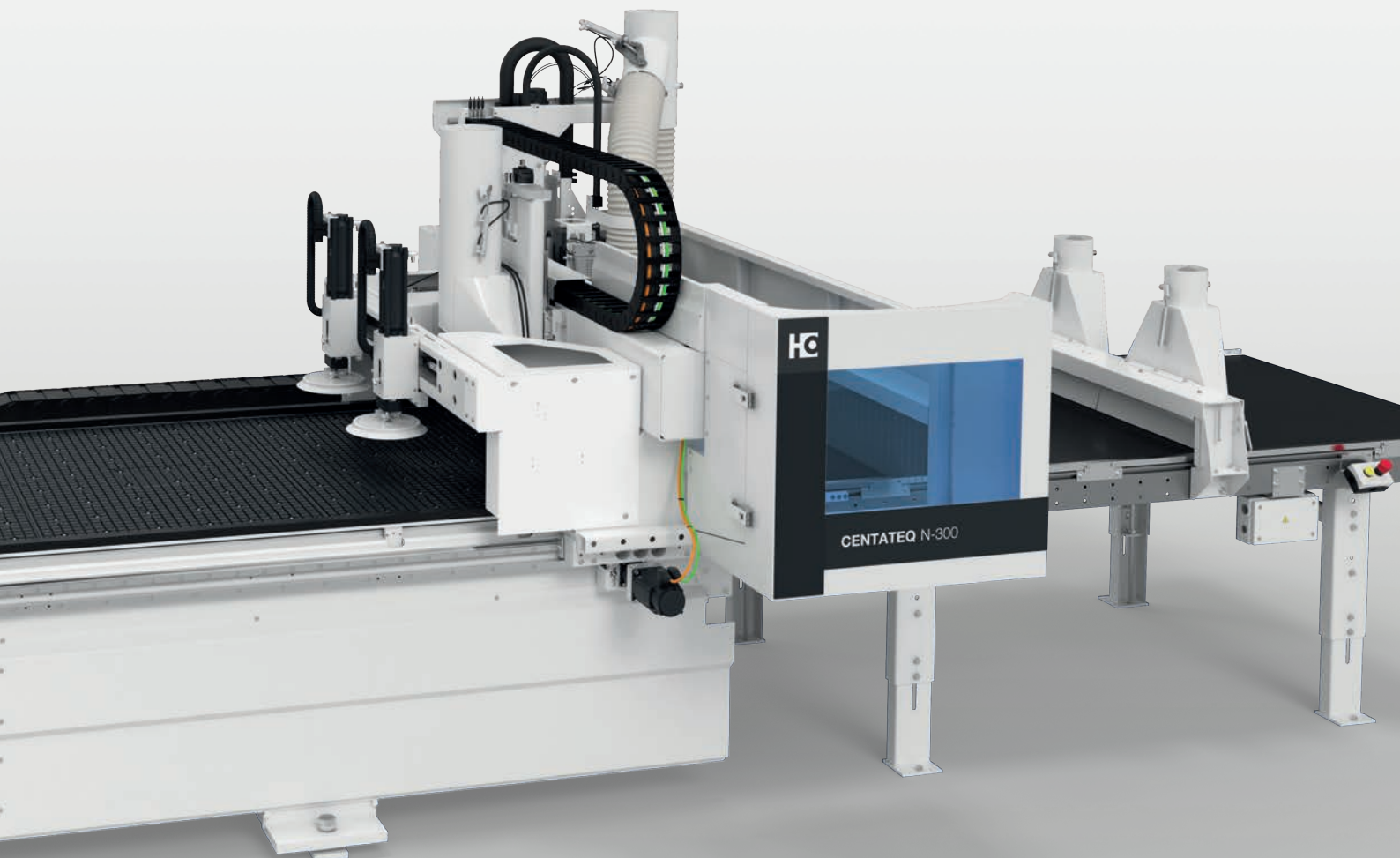





CENTATEQ N-300 – one action in action

Our nesting machines enable optimized cnc-processing and dividing of panels and other plateshaped materials. Various automation level for material handling enable productive and efficient production.

Typical applications for nesting: routing and vertical drilling of panel materials for cabinetry, doors and drawers, closet and storage solutions, furniture, store fixtures, work surfaces, plastics, composites and aerospace.

YOUR SOLUTION

MORE: [HOMAG.COM](https://www.homag.com)



CENTATEQ N-300

CONTENT

- 04 Highlights of the CENTATEQ N-300
- 06 Processing levels
- 07 Handling solutions
- 08 Table sizes
- 10 Configuration
- 14 Software
- 16 Technical Data
- 18 LifeCycleServices

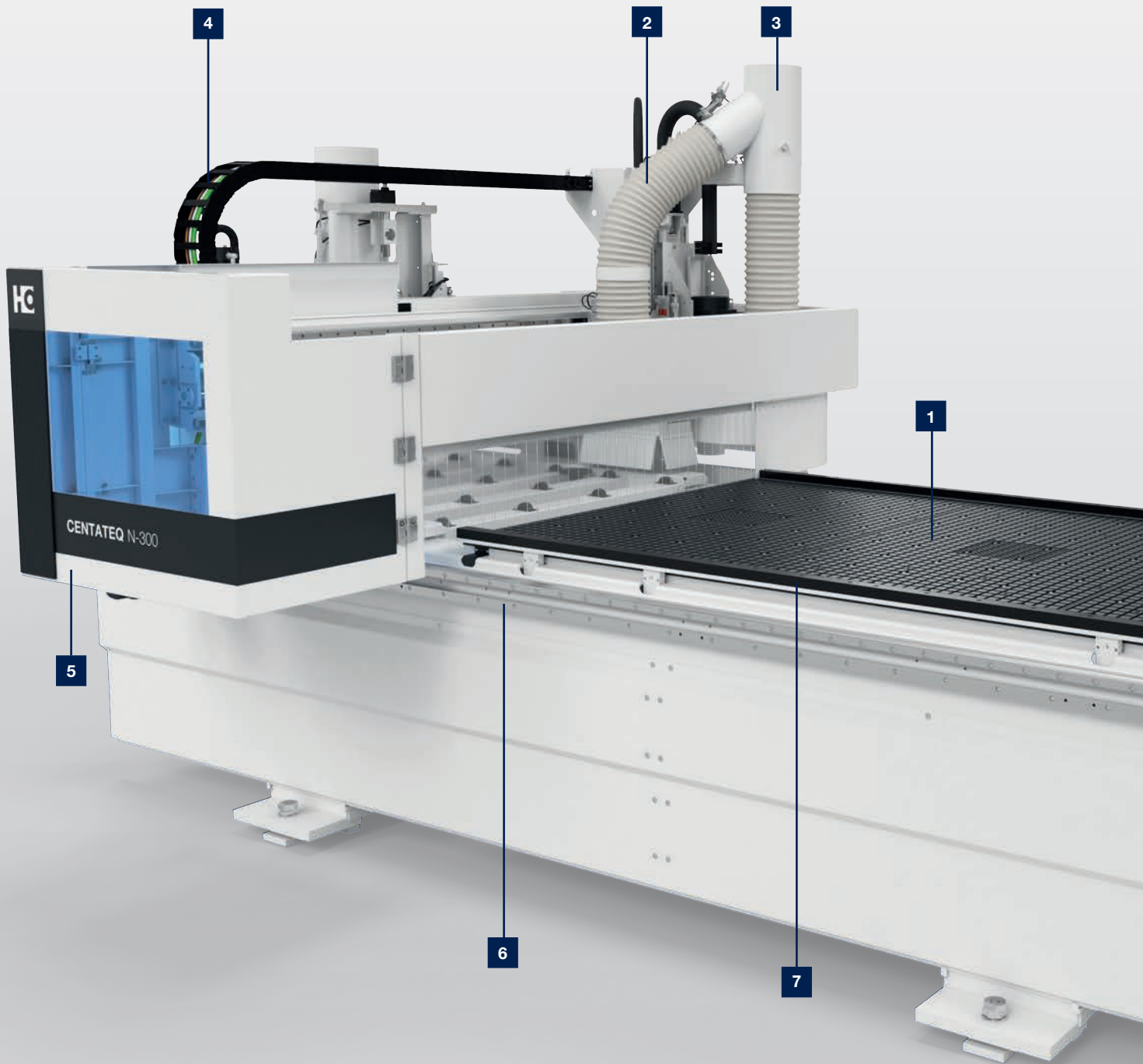

CENTATEQ N-300 – the compact nesting machine in gantry design

Our nesting machines enable optimized processing of panel materials. Various possibilities for the automation of material handling are available to increase efficiency and throughput. Typical applications for nesting: routing and vertical drilling

of panel materials for cabinetry, doors and drawers, closet and storage solutions, furniture, store fixtures, work surfaces, plastics, composites and aerospace.

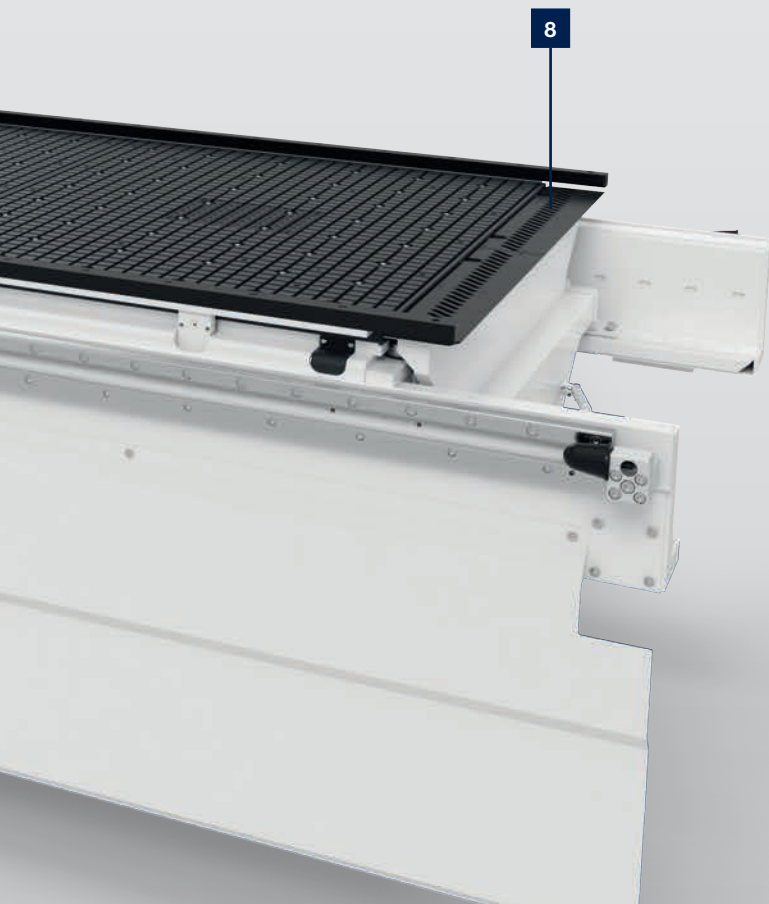

- 1 Effective vacuum due to advanced, and automatic MATRIX Pro Plus technology
- 2 Clean workpieces due to well-directed dust extraction system from above
- 3 Program-controlled extraction connection
- 4 Closed energy chains to protect cables and hoses
- 5 Easy access to spindle and drilling gear from front of the machine
- 6 High workpiece processing quality due to synchronous drive in combination with high precision linear guides
- 7 Stop System Basic / Extension stop system at the rear
- 8 Additional cleaning aid from bottom



Easy Entry

- Safety interlocked gantry door
- Easy access to main spindle and drill block



Tool pick-up station



- Allows machine to load its tool changer
- Eliminates operator error



powerControl with powerTouch

- 21,5" Full-HD multitouch display with wide screen 16:9
- Front USB interface
- Ethernet connection 10/100 Mbit

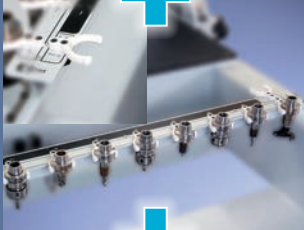
Choose your power processing level:

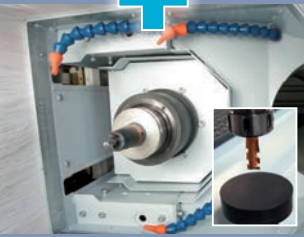
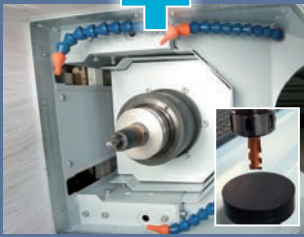
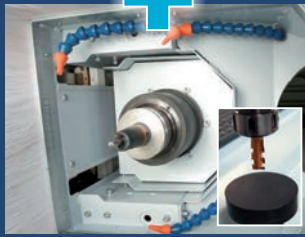
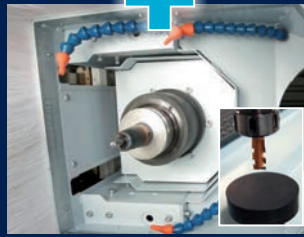
COMPACT PACKAGE	BASIC PACKAGE	FUTURE PACKAGE	PERFORMANCE PACKAGE
			
			
<ul style="list-style-type: none"> ▪ Tool changing system with tool pick-up station (480: 6 pick-up places / 510-512: 7 pick-up places) ▪ 13 HP (10 kW) HSK 63 routing spindle or 18 HP (13,2 kW) HSK 63 routing spindle with Air Jet Technology ▪ Tool length control 	<ul style="list-style-type: none"> ▪ 7 vertical drilling spindles ▪ Tool changing system with tool pick-up station (480: 7 pick-up places / 510-512: 8 and 612: 9 pick-up places) ▪ 13 HP (10 kW) HSK 63 routing spindle or 18 HP (13,2 kW) HSK 63 routing spindle with Air Jet Technology ▪ Tool length control 	<ul style="list-style-type: none"> ▪ 7 vertical drilling spindles ▪ 13-fold tool changer disc-type pick-up ▪ 13 HP (10 kW) HSK 63 routing spindle or 18 HP (13,2 kW) HSK 63 routing spindle with Air Jet Technology ▪ Tool length control 	<ul style="list-style-type: none"> ▪ 12 vertical drilling spindles ▪ 13-fold tool changer disc-type pick-up ▪ 13 HP (10 kW) HSK 63 routing spindle or 18 HP (13,2 kW) HSK 63 routing spindle with Air Jet Technology ▪ Tool length control

Choose your automation level:

TYPICAL APPLICATIONS FOR NESTING: routing and vertical drilling of panel materials for cabinetry, doors and drawers, closet and storage solutions, furniture, store fixtures, work surfaces, plastics, composites and aerospace.

Concept 3

- Optimized with new printing system

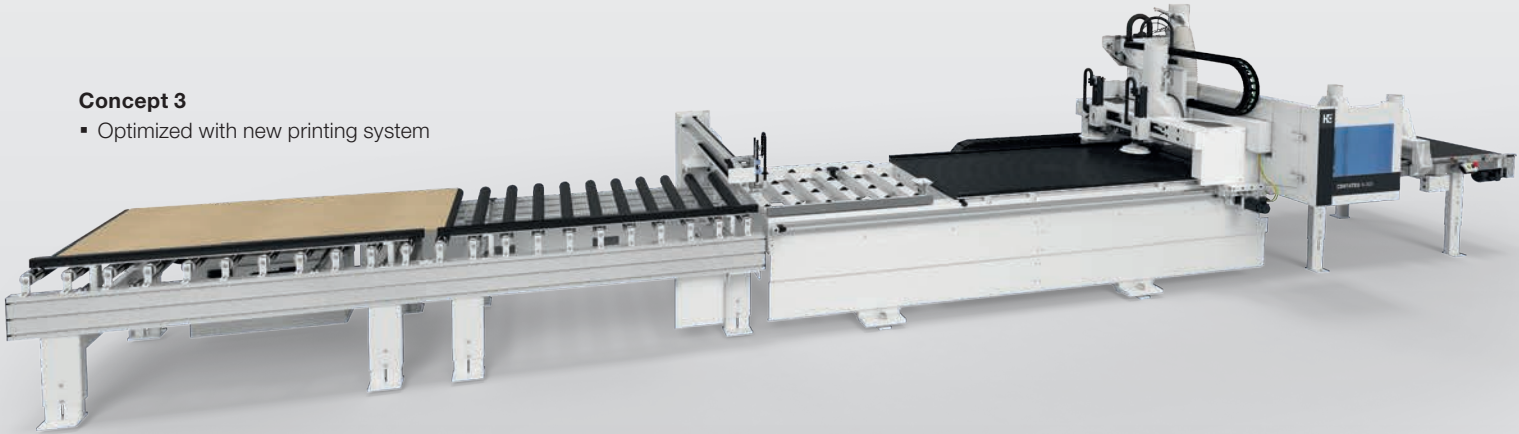

Handling solutions for CENTATEQ N-300

Compact machine (30% smaller footprint)	
Basic machine	
Handling Concept - Outfeed (Basic machine with outfeed belt)	
Handling Concept 1 (Automatic load/unload - prepared for external lift table, outfeed belt)	
Handling Concept 2 (Automatic load/unload from scissor lift or roller table, outfeed belt)	
Handling Concept 3 (Integrated labelling system, automatic load/unload from scissor lift or roller table, outfeed belt)	

Integration in
HOMAG Automation storage

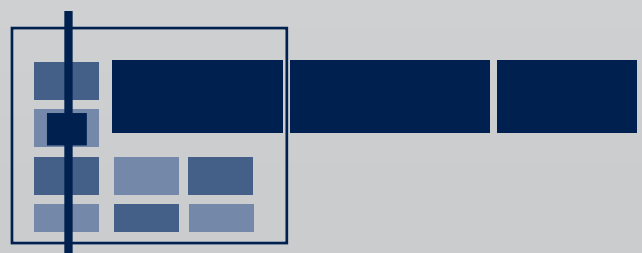

CENTATEQ N-300 – Efficient table field occupation by MATRIX Pro Plus

By selecting and deselecting the table field occupation, the vacuum is activated in the required area and is effective where it is needed. The areas are optimally matched to the established range of boards.

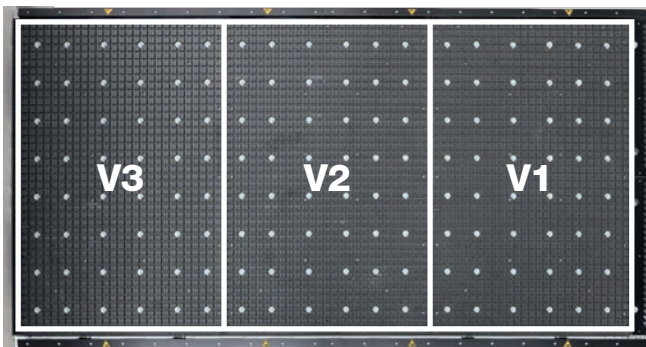

Segmentation of vacuum zones on the example of table size **1250 x 2520 mm | 4 x 8 ft**

- Segmentation in 3 fields
- 2,6 x 4 ft
- 5,2 x 4 ft
- 8,4 x 4 ft

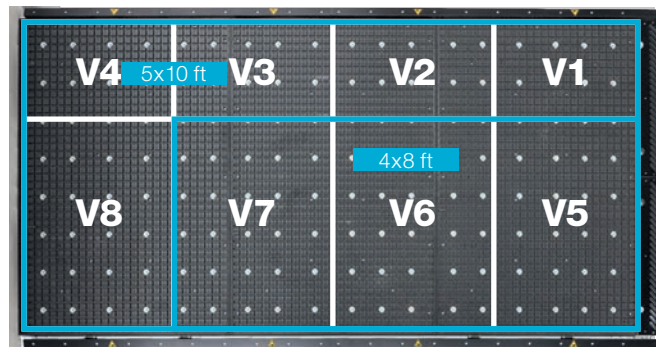

Segmentation of vacuum zones on the example of table size **1550 x 3100 mm | 5 x 10 ft**

- Segmentation in 8 fields
- 4 x 8 ft, 4 x 10 ft
- 5 x 8 ft, 5 x 10 ft

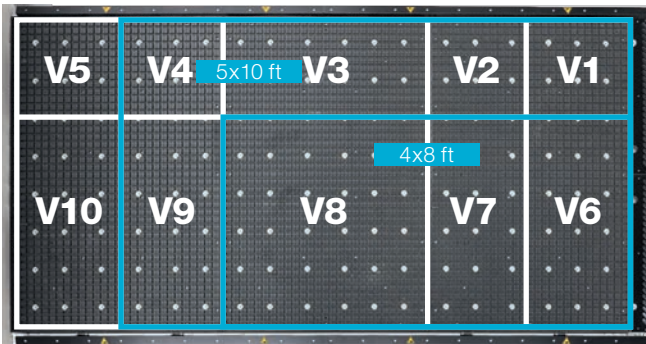

Segmentation of vacuum zones on the example of table size **1550 x 3700 mm | 5 x 12 ft**

- Segmentation in 10 fields
- 4 x 8 ft, 4 x 10 ft, 4 x 12 ft
- 5 x 8 ft, 5 x 10 ft, 5 x 12 ft

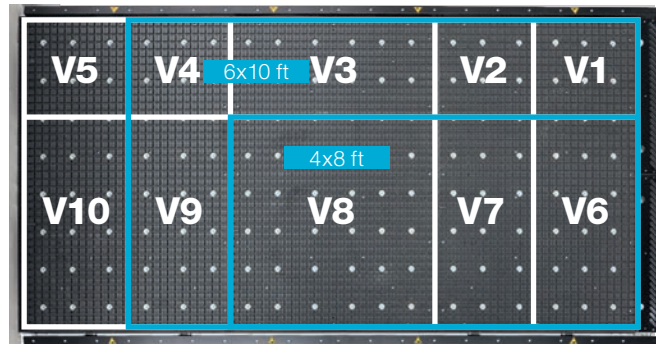

Segmentation of vacuum zones on the example of table size **1850 x 3700 mm | 6 x 12 ft**

- Segmentation in 10 fields
- 4 x 8 ft, 4 x 10 ft, 4 x 12 ft
- 6 x 8 ft, 6 x 10 ft, 6 x 12 ft

Different sizes for different applications: it's your choice

Nesting machines are utilized across a wide variety of market segments. We see nested based manufacturing strategies employed in the production of cabinetry, doors and drawers, closets and storage, furniture, store fixtures, work surfaces, plastics and composites, non-ferrous metals, as well as aerospace.

The CENTATEQ MATRIX Pro Plus table system is perfectly suited to handle the raw material variance noted by some of today's multi-faceted manufacturers. The solution reads the raw board size of the incoming program and automatically concentrates vacuum pressure to the correct area of the machine, limiting machine setup time. Vacuum zones can also be manually selected at the machine control.

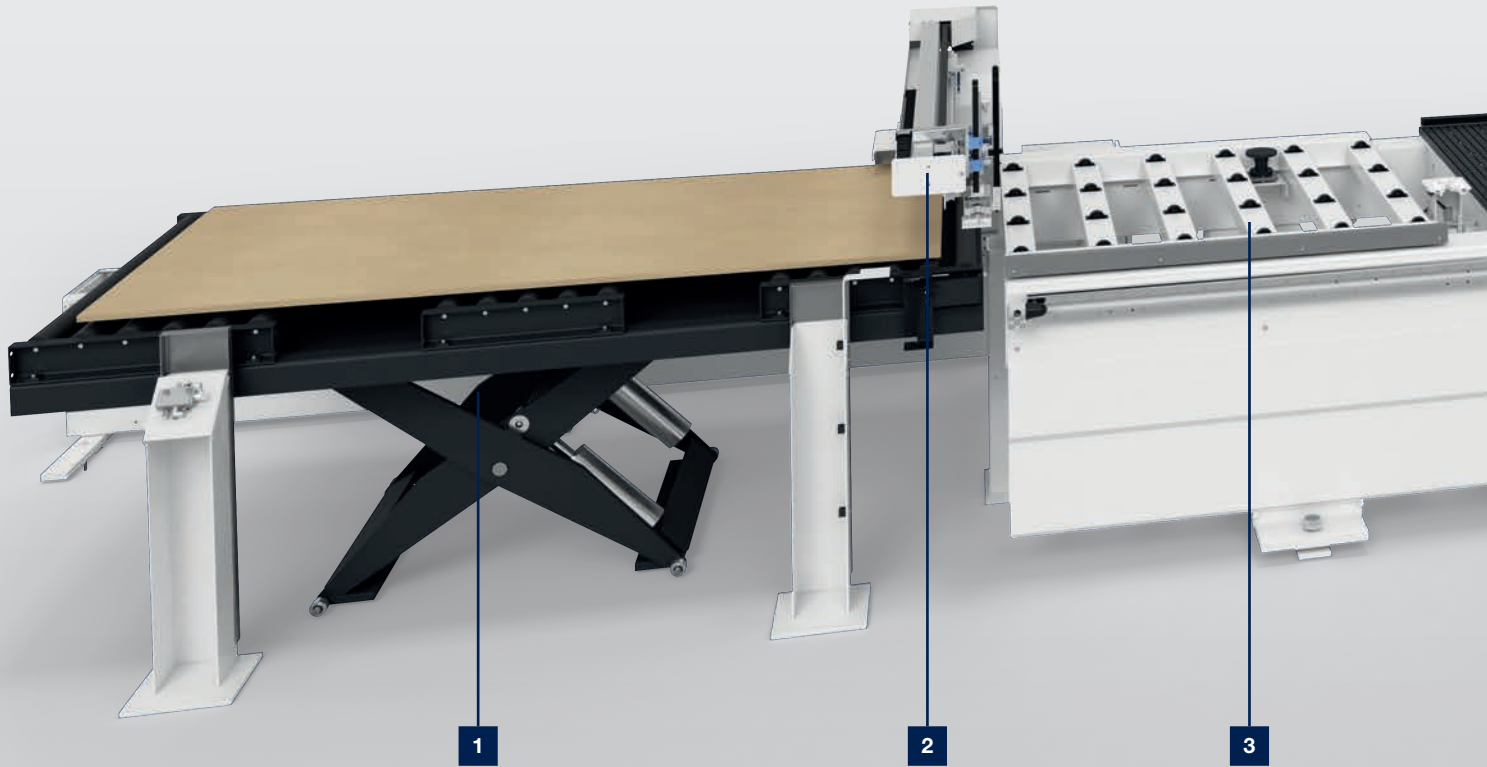

6

different automation levels

4

configurations

4

table sizes

100

More than
variations to suit your need.

CENTATEQ N-300 –
Configuration overview of
material handling concepts

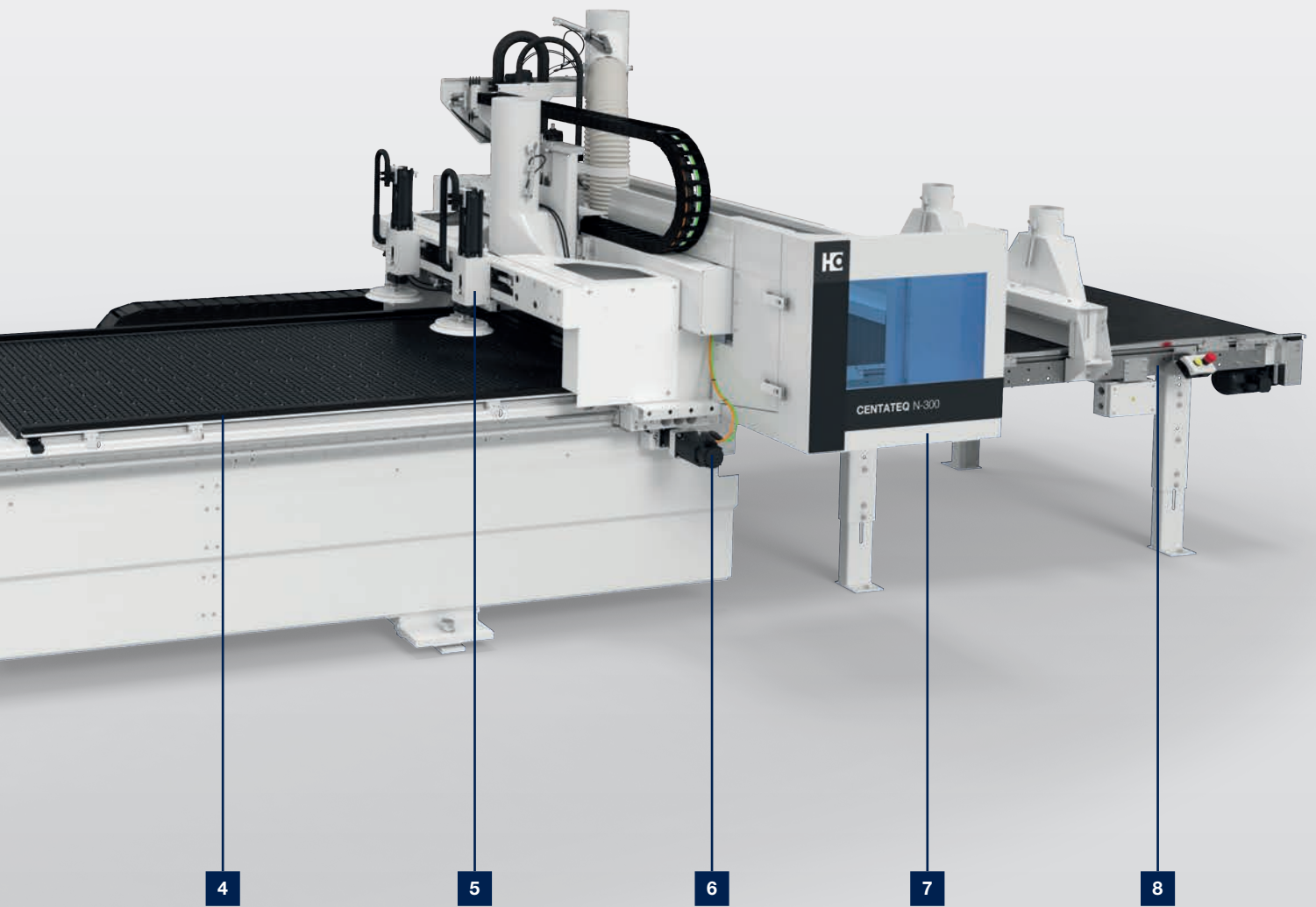

- 1** Lifting table for easy infeeding or frequency-controlled roller table
- 2** Automatic Label Printing for precise handling and identification of the workpieces
- 3** Intermediary transfer rollers to prevent scratching during the loading process
- 4** Lowerable fence guide and program-controlled positioning
- 5** The vacuum arm takes over a pre-positioned raw board and aligns this against the end of the table in X-direction
- 6** 2 synchronized X-drives guarantee highest processing quality
- 7** Easy entry through hinged machine cover
- 8** Outfeed transport belt

CENTATEQ N-300 | Everything at a glance...

You have free choice. A package is available for all common requirements. This leaves nothing to be desired.

	Table sizes				Processing level					Tool changing system with pick-up				Tool changer disk type with pick-up	Transport belt		Transfer rollers
	4 x 8 ft	5 x 10 ft	5 x 12 ft	6 x 12 ft	Compact package	Additional drilling gear	Basic package	Future package	Performance Package	4 x 8 ft	5 x 10 ft	5 x 12 ft	6 x 12 ft		Transport belt	Transfer rollers	
Compact machine	●	●	●	-	●	○	-	-	-	6	7	7	-	-	-	-	
Basic machine	●	●	●	●	-	-	●	●	●	7	8	8	9	-	-	-	
Handling Concept Outfeed	●	●	●	●	-	-	-	●	●	-	-	-	-	13	✓	-	
Handling Concept 1	●	●	●	●	-	-	-	●	●	-	-	-	-	13	✓	✓	
Handling Concept 2	●	●	●	●	-	-	-	●	●	-	-	-	-	13	✓	✓	
Handling Concept 2R	●	●	●	●	-	-	-	●	●	-	-	-	-	13	✓	✓	
Handling Concept 3	●	●	●	●	-	-	-	●	●	-	-	-	-	13	✓	✓	
Handling Concept 3R	●	●	●	●	-	-	-	●	●	-	-	-	-	13	✓	✓	

Compact Package incl.	-	Rack tool change system	13 HP (10 kW) or 18 HP (13,2 kW) routing spindle
Basic Package incl.	7 vertical drilling spindles	Rack tool change system	13 HP (10 kW) or 18 HP (13,2 kW) routing spindle
Future Package incl.	7 vertical drilling spindles	13-fold tool changer disc-type	13 HP (10 kW) or 18 HP (13,2 kW) routing spindle
Performance Package incl.	12 vertical drilling spindles	13-fold tool changer disc-type	13 HP (10 kW) or 18 HP (13,2 kW) routing spindle

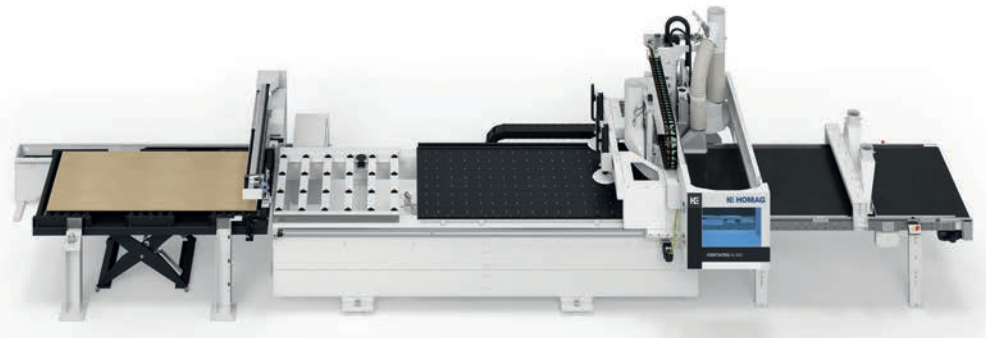

Automation level			Equipment													
Lifting table	Infeed roller table	Barcode printer	tapio-ready	PowerControl with powerTouch	Synchronous drive	Vacuum arms for positioning	Push-off-device	Dust extraction outfeed from below	Dust extraction outfeed from top	Vacuum system	Vacuum cups	Air cushion function	Air Conditioning	Label printing terminal	Push & pull	Loading of the liftable from front and rear
-	-	-	✓	✓	✓	-	-	-	-	○	○	○	○	○	-	-
-	-	-	✓	✓	✓	-	-	-	-	○	○	○	○	○	-	-
-	-	-	✓	✓	✓	✓	✓	✓	○	○	○	○	○	○	○	-
-	-	-	✓	✓	✓	✓	✓	✓	○	○	○	○	○	○	○	-
✓	-	-	✓	✓	✓	✓	✓	✓	○	○	○	○	○	○	○	○
-	✓	-	✓	✓	✓	✓	✓	✓	○	○	○	○	○	○	○	-
✓	-	✓	✓	✓	✓	✓	✓	✓	○	○	○	○	○	○	○	-
-	✓	✓	✓	✓	✓	✓	✓	✓	○	○	○	○	○	○	○	-

Standard: ✓ Available: ● Option: ○

- Tool length control
- Tool length control
- Tool length control
- Tool length control

Software | Machine

Our machines are equipped with everything needed for productive use as standard. In addition, a wide range of software modules can be supplemented to create the optimum configuration.

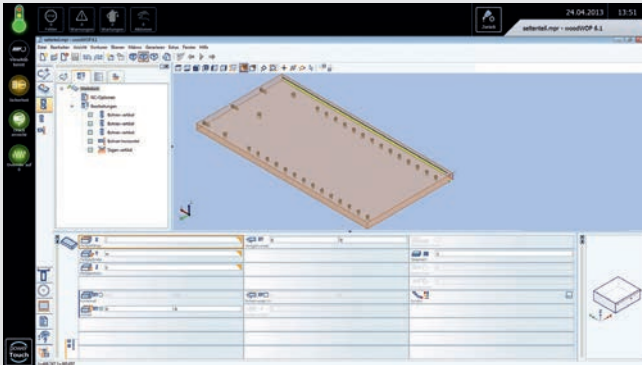

woodWOP

- Modern software based on Windows®
- Import of CAD files in DXF format
- More than 30.000 installations worldwide
- Worldwide largest forum for woodWOP

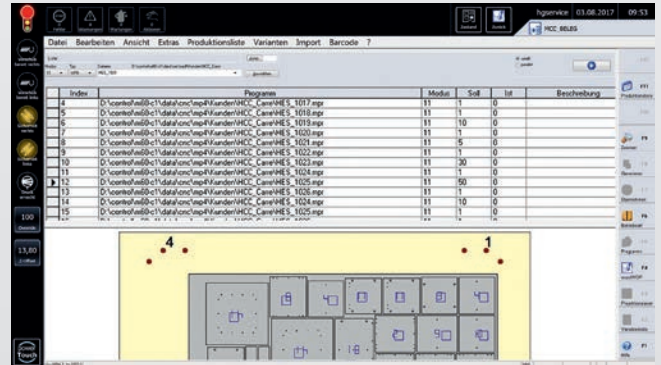

Production list software

- For management and creation of product lists for individual manufacturing

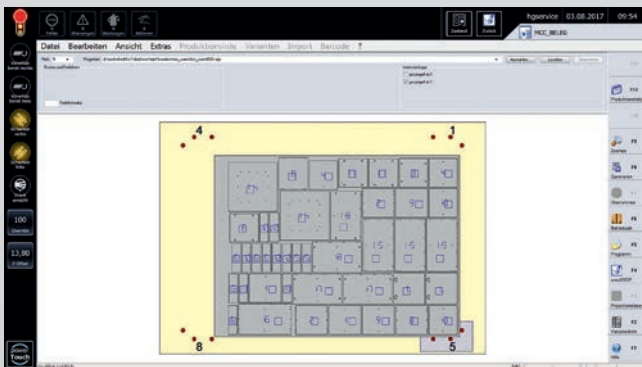

MCC

- Simple control of main machine functions through soft keys
- Graphical loading



Machine data recording Basic

- Machine Data Recording – collecting and evaluating machine states via time meter and event meter
- Display and logging of maintenance measures

Process optimization

CUT RITE, THE OPTIMIZATION SOFTWARE OF THE HOMAG, is used for cutting boards on sawing machines as well as nesting machines. The modular structure of the software allows users already controlling their sawing machine via Cut Rite to integrate the nesting module without problems. Plus, customer processes can be made even more efficient by woodCAD|CAM and residual parts management.

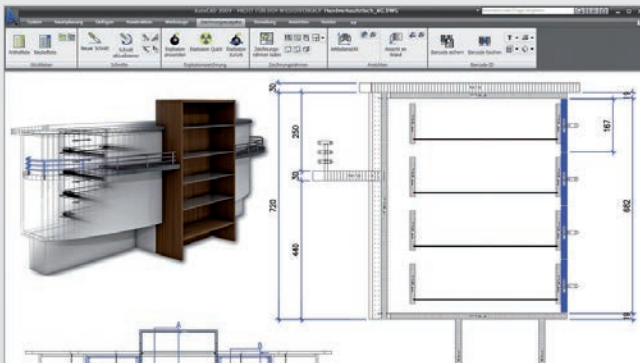

woodCAD|CAM

- Parametric design in 3D
- Seamless data flow in operation
- Bill of materials, cutting to size and cost estimation
- CNC data for HOMAG Group machines
- Barcode generation
- Photorealism for sales negotiations

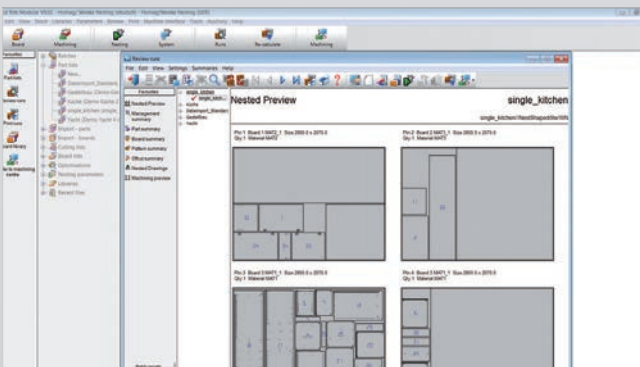

Optimization software: woodNest Basic and Cut Rite Nesting

- Optimization and generation of cutting plans for rectangular and free-formed workpieces (woodNest Basic: manually | Cut Rite: automatically)
- Functions with Cut Rite:
 - Import of parts lists, e.g. from Excel, or direct import of woodWOP programs
 - Additional milling strategies “bars”, “common line” and “stay down”
 - Includes material management, parts sorting by material type, and label printing in the office
 - Manual editing of cutting plans

Technical Data

Our machines are equipped with everything needed for safe and effective operation.

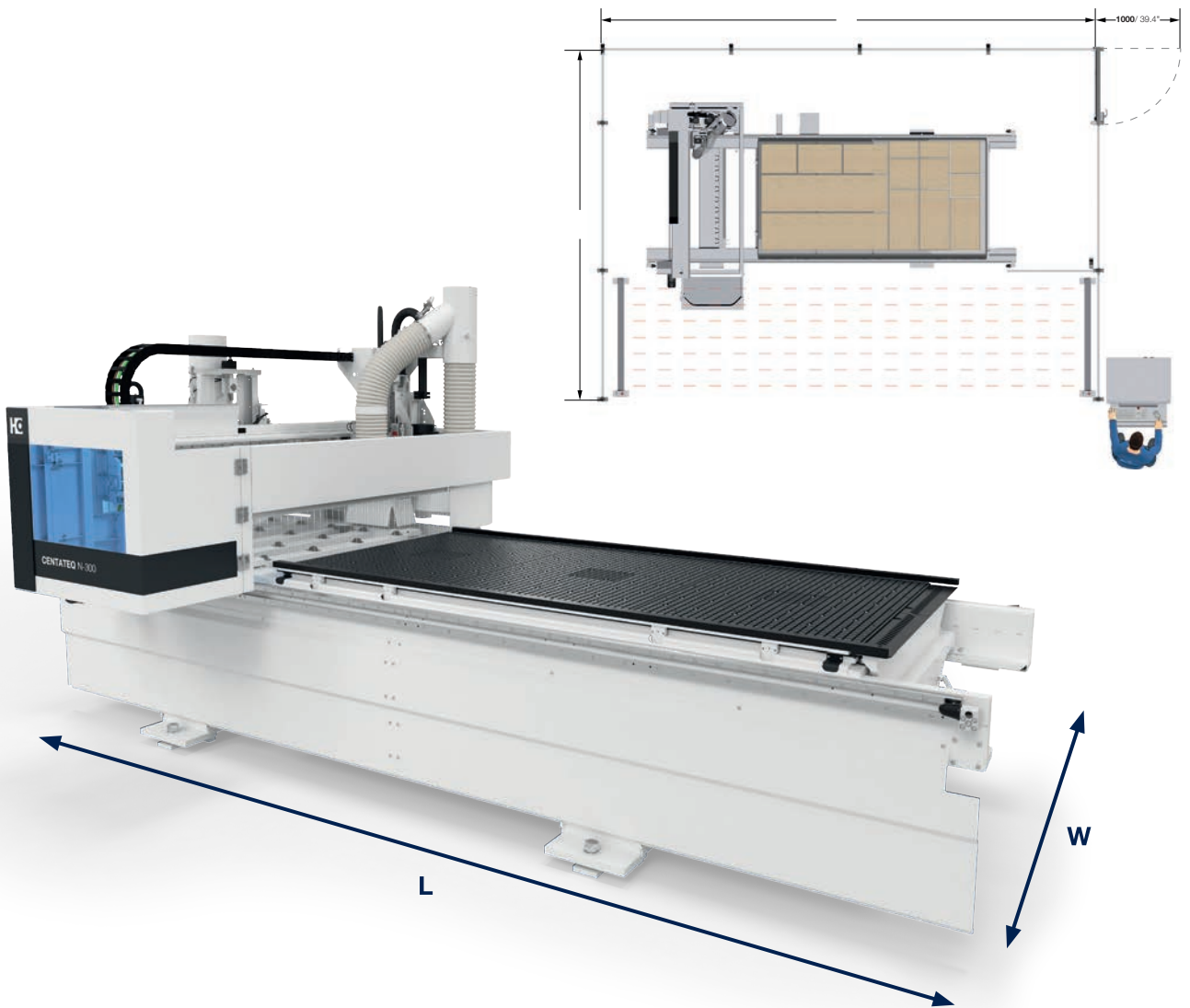

Vector speed X/Y - Z-axis	m/min	96 - 25
Compressed air connection	inch	R ½
Compressed air required	bar	7
Dust extraction port	mm	Ø 200*
Dust extraction volume	m³/h	min. 3170**
Electrical power – total connection load	kW	27.5**

** Basic Machine

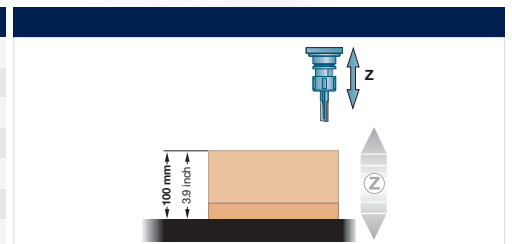

		X	Y	Z
Working field	Table 4 × 8 ft	2520 / 99.2	1250 / 49.2	100 / 3.9
	Table 5 × 10 ft	3100 / 122.0	1550 / 61.0	100 / 3.9
	Table 5 × 12 ft	3700 / 145.7	1550 / 61.0	100 / 3.9
	Table 6 × 12 ft	3700 / 145.7	1850 / 72.8	100 / 3.9
Travel range	Table 4 × 8 ft	3710 / 146.1	1660 / 65.4	245 / 9.6
	Table 5 × 10 ft	4300 / 169.3	1965 / 77.4	245 / 9.6
	Table 5 × 12 ft	4900 / 193.0	1965 / 77.4	245 / 9.6
	Table 6 × 12 ft	4900 / 193.0	2257 / 88.9	245 / 9.6
				mm / inch

		L	W		
Floor space	Manual Concepts*				
	Compact Machine	Table 4 × 8 ft	5300 / 208.7	3800 / 149.6	
		Table 5 × 10 ft	5880 / 231.5	4080 / 160.6	
		Table 5 × 12 ft	6480 / 255.1	4080 / 160.6	
	Basic Machine	Table 4 × 8 ft	6580 / 259.1	4420 / 172.0	
		Table 5 × 10 ft	7080 / 278.7	4880 / 192.1	
		Table 5 × 12 ft	7580 / 298.4	4880 / 192.1	
		Table 6 × 12 ft	7580 / 298.4	5130 / 202.0	
	Handling Concept Outfeed	Table 4 × 8 ft	8100 / 318.9	4420 / 172.0	
		Table 5 × 10 ft	9800 / 385.8	4880 / 192.1	
		Table 5 × 12 ft	10290 / 405.1	4880 / 192.1	
		Table 6 × 12 ft	10290 / 405.1	5130 / 202.0	
	Automatic Concepts*				
	Handling Concept 1	Table 4 × 8 ft	8320 / 327.6	4420 / 172.0	
		Table 5 × 10 ft	10050 / 395.7	4880 / 192.1	
		Table 5 × 12 ft	10540 / 415.0	4880 / 192.1	
		Table 6 × 12 ft	10540 / 395.7	5130 / 202.0	
	Handling Concept 2	Table 4 × 8 ft	10300 / 405.5	4420 / 172.0	
		Table 5 × 10 ft	12550 / 494.1	4880 / 192.1	
		Table 5 × 12 ft	13790 / 542.9	4880 / 192.1	
		Table 6 × 12 ft	13790 / 542.9	5130 / 202.0	
	Handling Concept 2R	Table 4 × 8 ft	11800 / 464.6	4420 / 172.0	
		Table 5 × 10 ft	13950 / 549.2	4880 / 192.1	
		Table 5 × 12 ft	14660 / 577.2	4880 / 192.1	
		Table 6 × 12 ft	14660 / 577.2	5130 / 202.0	
	Handling Concept 3	Table 4 × 8 ft	11040 / 434.6	4420 / 172.0	
		Table 5 × 10 ft	13100 / 515.7	4880 / 192.1	
		Table 5 × 12 ft	14290 / 562.6	4880 / 192.1	
		Table 6 × 12 ft	14290 / 562.6	5330 / 209.8	
	Handling Concept 3R	Table 4 × 8 ft	13400 / 527.6	4420 / 172.0	
		Table 5 × 10 ft	15300 / 602.4	4880 / 192.1	
		Table 5 × 12 ft	15840 / 623.6	4880 / 192.1	
		Table 6 × 12 ft	15840 / 623.6	5330 / 209.8	mm / inch

*Subject to technical changes



HOMAG LifeCycleServices

The sale of our machines comes with all-in optimum service backup and individual advice. We support you with service innovations and products which are especially tailored to your requirements. With short response times and fast customer

solutions we guarantee consistently high availability and economical production – over the entire life cycle of your machine.



Remote Service

- Hotline support via remote diagnosis regarding control, mechanics and process technology. Thus the on-site service can be reduced by 90 %!
- Mobile applications such as ServiceBoard reduce the costs through fast help in case of troubles by mobile live video diagnosis, online service message and the online spare parts shop eParts



Spare Parts Service

- Identify, request and order spare parts around the clock via www.eParts.de
- Local availability of parts offered by our sales and service companies as well as sales and service partners all over the world
- Reduction of downtimes through defined spare parts and wear parts kits



Modernization

- Keep your machinery up-to-date and increase your productivity as well as your product quality. This is how you can meet tomorrow's requirements today!
- We support you with upgrades, modernization as well as individual consultancy and developments



**HOMAG Finance –
precisely the right financing**

- We offer you tailored financing proposals for your machinery or plants. Our financial advice goes hand in hand with our expertise relating to technical questions. Your personal contact person will take care of the whole process.
- The benefit for you: The ability to invest without delay in new technologies and remain financially flexible.

1.200
Service employees around the world

5.000
Customers in training courses / year

> 90%
less on-site-services through successful remote diagnosis

> 150.000
machines, all electronically documented in 28 different languages – in eParts



Training courses

- The trainings perfectly suit to your requirements. Through this your machine operators can operate and maintain the HOMAG Group machines optimally.
- The training courses also include customer-specific training documents with practice-proven exercises

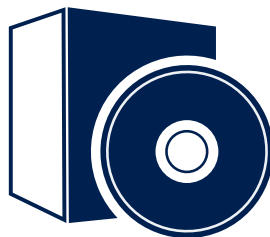

Software

- Telephone support and consultancy through software support
- Digitalization of your sample parts via 3D scanning saves time and money compared to new programming
- Subsequent networking of your machinery with intelligent software solutions ranging from construction to production



Field Service

- Increased machine availability and product quality by certified service staff
- Regular checks through maintenance / inspection guarantee the highest quality of your products
- We offer you the highest availability of technicians in order to reduce downtimes in case of unpredictable troubles

HOMAG Group AG

info@homag.com

www.homag.com



YOUR SOLUTION