

FANUC

iD SERIES WIRE EDM

α -iD



FANUC α -iD Series



FANUC i D Series Wire EDM machines have been completely re-engineered from the ground up for superior cutting speed and accuracy, surface finishes, economy of operation and ease of maintenance. Above all, they offer the exceptional reliability for which FANUC is known. So, if you need a dependable, versatile, precision wire EDM, the new FANUC i D Series offers **performance without the fuss!**

- High-performance CNC coupled to digital servo technology
- Extremely rigid thermally insulated base casting
- Designed for high cutting speeds and exceptional reliability
- Advanced AWF enables extended unmanned operation



FANUC 310iS-WA... the World's Most Powerful EDM CNC

- Control up to 16 axes
- Large 15" touch panel LCD
- Easy to operate
- USB and ethernet I/Os



Excellent Economy

- Longer consumable life
- Lower running cost
- Lower maintenance
- Compact space-saving design

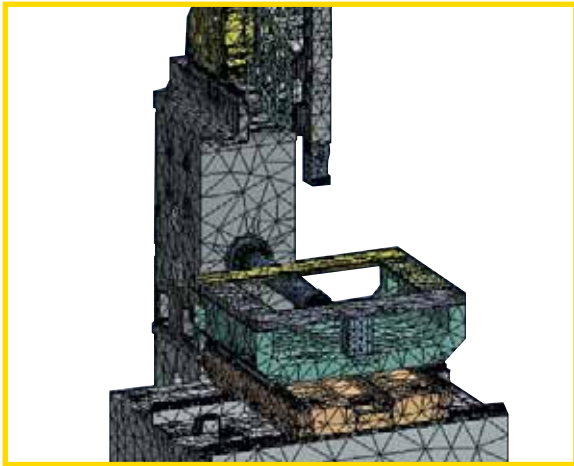

High Precision

- New thermally insulated high-rigidity casting
- Linear glass scales (X & Y)
- Upgraded AI pulse control
- Twin servo wire tension control
- Inverter-controlled water temperature management
- Servo water level control



Long Axis Travels

Model	X x Y x Z Axis
0iD-10	in: 14.5 x 10.6 x 10.2 mm: 370 x 270 x 260
1iD-12	in: 23.6 x 15.7 x 12.2 mm: 600 x 400 x 310
1iD-16	in: 23.6 x 15.7 x 16.2 mm: 600 x 400 x 412



High Reliability

- Air jet AWF
- Dual servo tensioning system
- No-drag seal plate structure
- 100% Made in Japan

High-Speed, High-Precision Cutting with AI Pulse Control

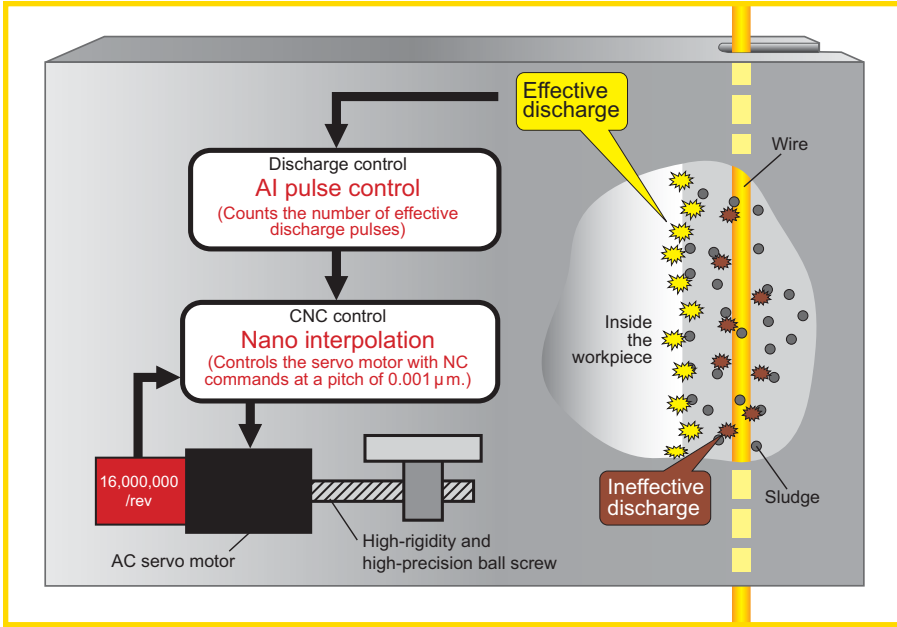

AI Pulse Control

- "R" Technology improves accuracy and surface finishes, reduces number of passes
- Accurately counts the number of effective discharge pulses and maximizes cutting speed without sacrificing precision
- Ensures uniformity of energy density and discharge gap, enabling high-precision cutting at high speeds
- Improved discharge monitoring cycle is 4 times faster than that of conventional machines
- Direct servo control in real-time (not via the CNC) enables greater accuracy at higher cutting speeds

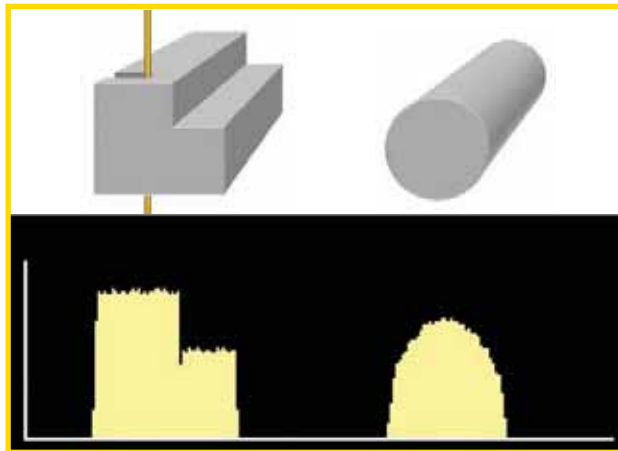

Multi-Level Figures

- AI pulse control optimizes cutting speeds even on stepped, multi-level or irregularly shaped figures

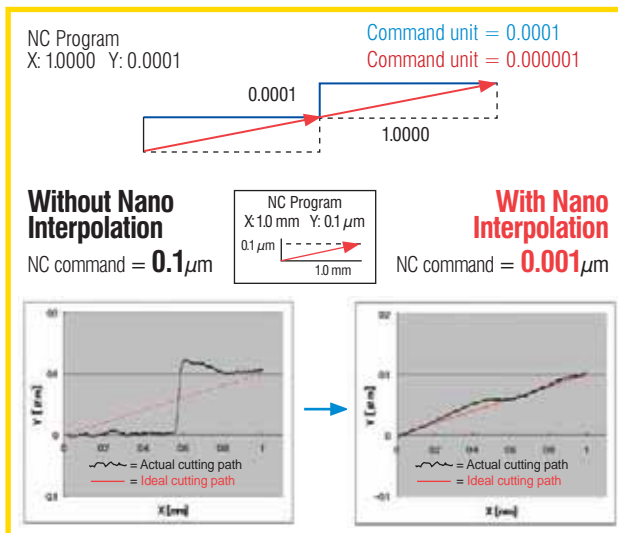

Nano Interpolation

- CNC issues commands to the servo in nanometers ($0.001\mu\text{m}$)
- Eliminates the accumulation of axis movement errors
- Smoother axis movement improves part precision

AGGURAGY

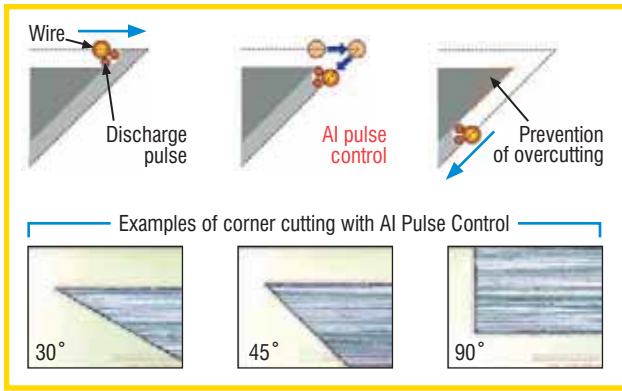

AI Corner Control

- Accurately controls discharge energy and cutting speed to ensure high-precision corners
- Prevents undercutting

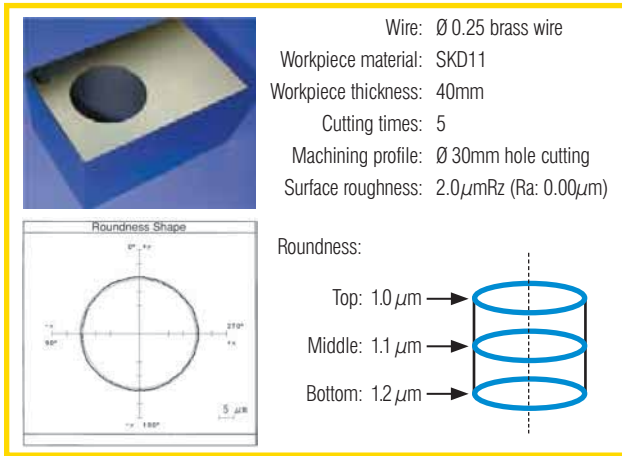

Excellent Circularity

- AI Pulse Control and nano interpolation enable smooth axis motion — even at high speeds — for excellent circularity

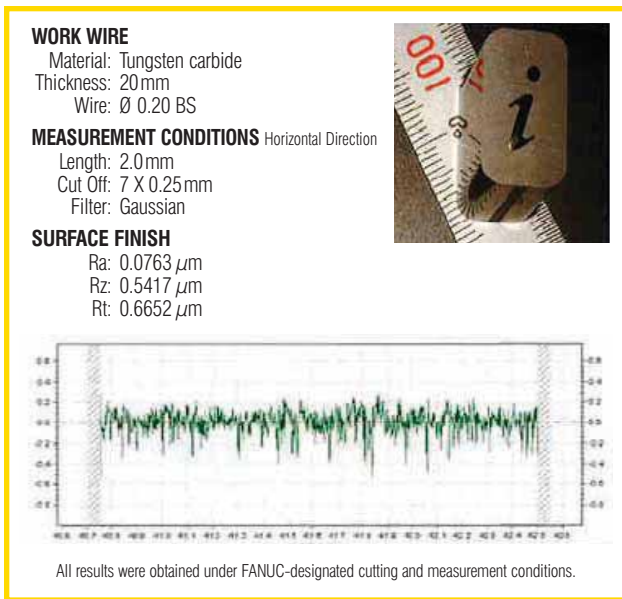

Superior Surface Finishes

- Optional microfinish (MF) power supply delivers extra-fine discharge for surface finishes to 1.5 µmRz or better
- With an isolation jig, finishes to 0.7 µmRz or better can be achieved

Cutting Samples

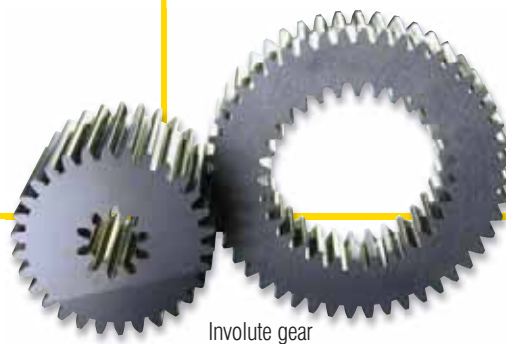

Rigid Construction and Engineering Enhancements Ensure Greater Stability and Smoother Cutting



High-Rigidity Casting

- Symmetrical CAD-designed casting is 40% more rigid than prior models
- Thermal compensation ensures machining accuracy
- Pyramid machine design and oversized bed eliminate table overhang for greater cutting rigidity — even with heavy workpieces



Improved Lower Guide Assembly

- Improved lower guide construction increases rigidity
- Eliminates heat source
- Sealed bearing for longer life

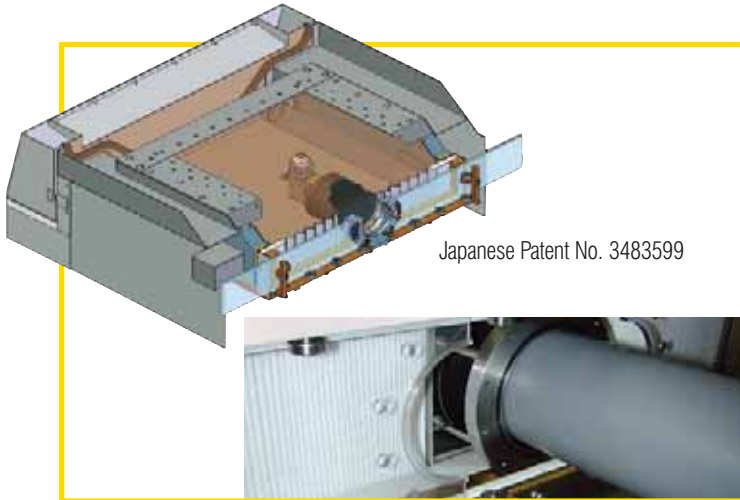

Patented Seal Plate Design

- Clean water chamber reduces accumulation of cutting debris (swarf) on the seal
- Prevents loss of cutting precision due to increased resistance
- Eliminates V-pack seals around lower arm
- Partitioned transparent seal plate for easy maintenance
- Clear plate readily shows dirt deposits and indicates need to clean the unit



Inverter-Controlled Cooling System

- High-precision inverter-controlled chiller system provides dielectric fluid temperature control to $\pm 0.1^{\circ}\text{C}$

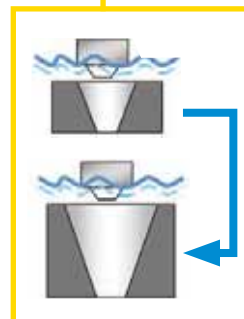

AC Servo Water Level Control

- Servo-driven drain gate eliminates shock due to solenoid operation
- Minimizes resulting lines on workpiece
- Ensures optimum water levels for varying thickness workpieces

PRECISION

Redesigned AWF Provides Flawless 10-Second Threading and Precise Wire Tension Control

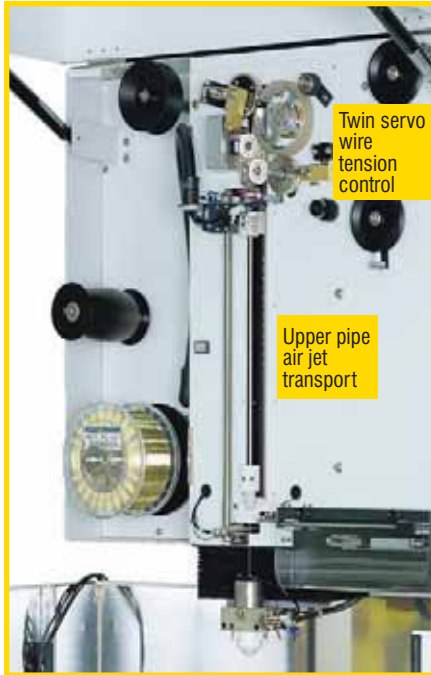

Air Jet AWF

- High-speed AWF delivers flawless wire feeding in 10 seconds or less
- New air jet transport system for upper pipe improves AWF accuracy, reliability, and speed
- A unique thermal fusion and annealing system guarantees straight and very sharp wire
- Anneals wire across full Z-axis travel
- .004" - .012" wire capable

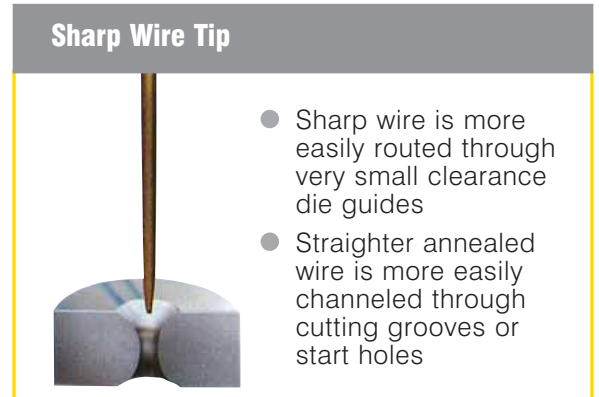
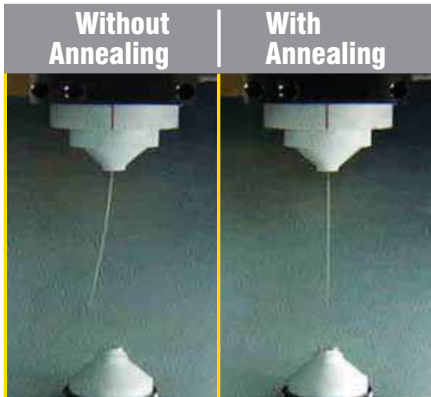
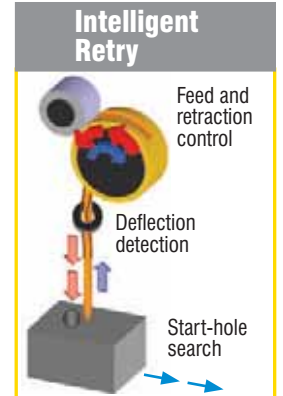
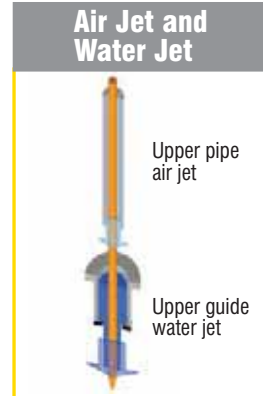
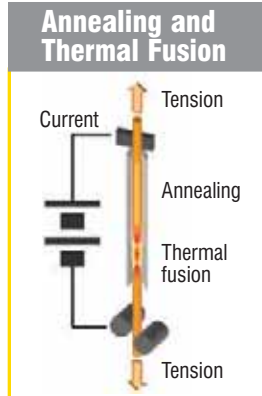

Twin AC Servo Wire Tension Control

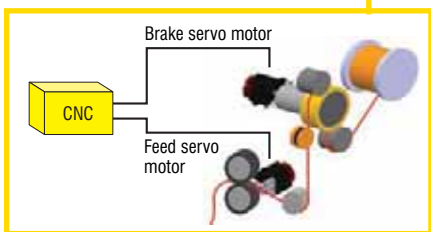

- Reduces tension variations to 1/4 those of conventional machines and improves cutting accuracy and surface finish

AI Wire Break Repair Function

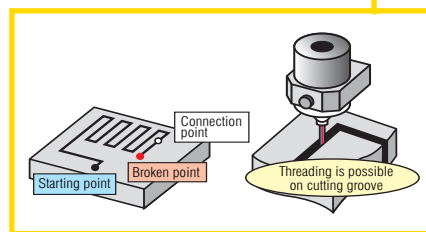

- Ideal when the wire kerf narrows due to workpiece distortion or swarf
- Reduces rethreading time by eliminating need to return to start hole position

- Rethreads wire near the break point without returning to start hole position



Powerful New CNC Simplifies Programming, Operation, and Maintenance



Large 15" Touch Screen

- Larger LCD touch screen displays considerably more information for faster, easier operation
- One-touch screen selection using dedicated menu keys
- Split-screen feature displays more information

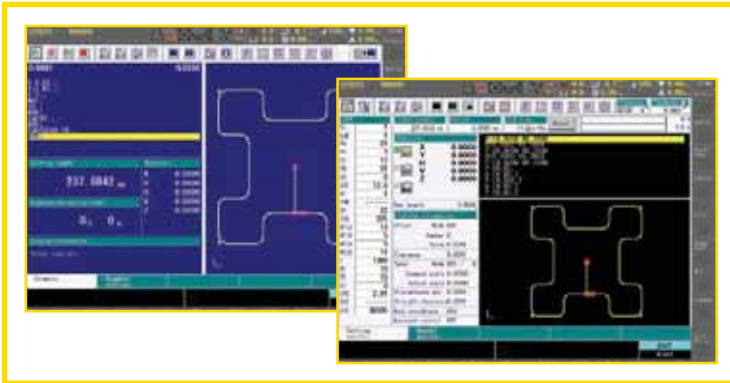

Simple, Yet Sophisticated Drawing

- Speeds drawing even of extremely detailed work pieces
- Indicator shows actual cutting wire position in real-time
- Auto-pan feature continually recenters drawing during cutting process

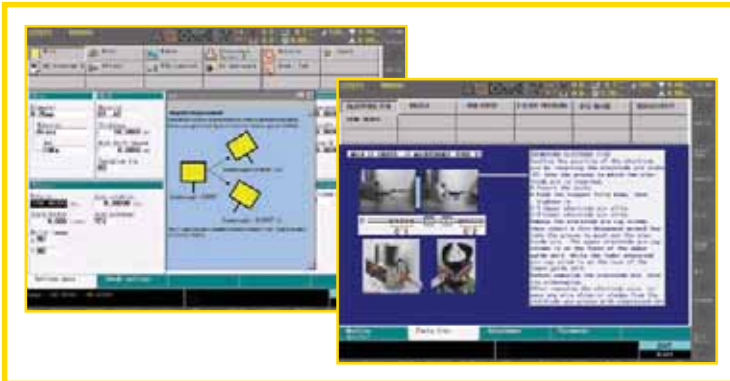

Setup and Maintenance

- Special screens allow faster machine and part setups
- Reminder screens prompt scheduled routine maintenance and alarms indicate the need for immediate action

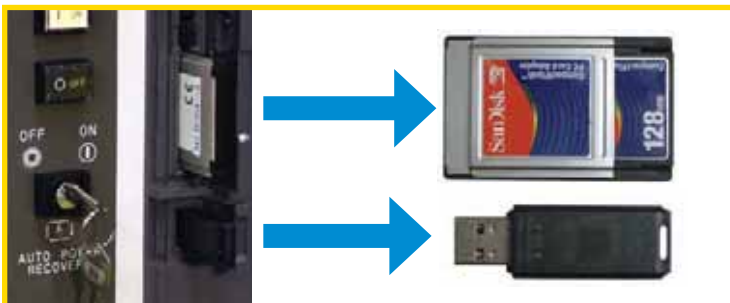

Easily Accessible Universal Input/Outputs

- Programs or data can be easily input or saved using removable media such as USB memory sticks or compact flash cards
- Ethernet port for network I/O

POWERFUL

Remote Monitoring and Programming

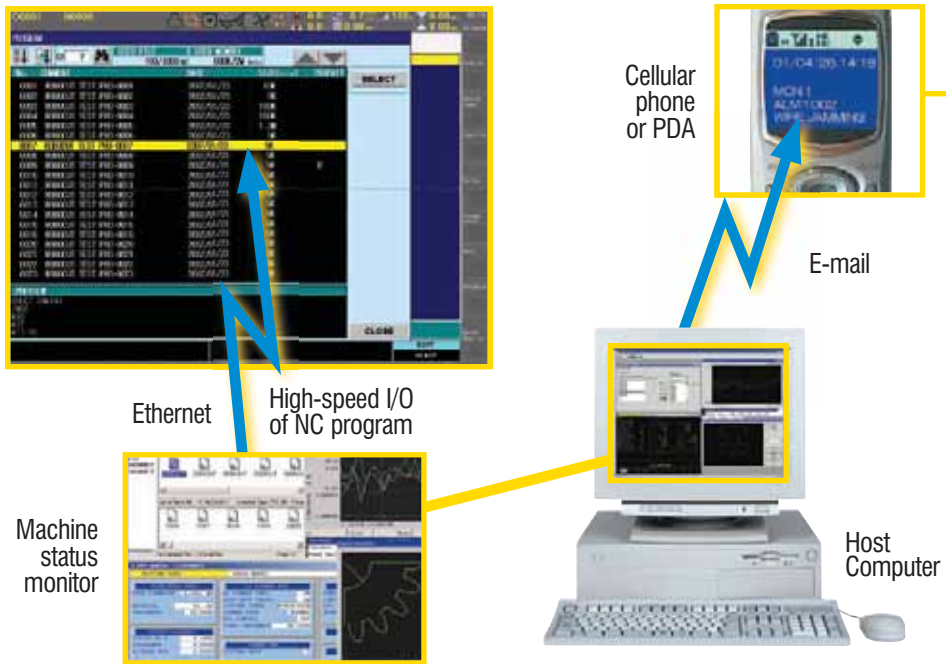

CUT MONITOR *i* Remote Monitoring System

- Cut Monitor *i* System enables remote real-time machine/job status monitoring and recording
- Allows operator to make remote changes to cutting conditions and to send/receive CNC programs
- Notifies operator of machine alarms or successful job completion through e-mails to computers, cell phones, or PDAs

Robotic Automation



Robotic Cell

- Floor-, overhead-, or track-mounted robot enables automatic loading and unloading of workpieces for extended unmanned operation
- Exclusive cell control software simplifies scheduling, monitoring, and tracking of machines/jobs; allows flexible queuing of different job types



Methods EDM Training and Service

With 7 regional technical centers and a national network of knowledgeable dealers, Methods EDM can provide operator training, technical support, upgrades, parts, and service to maximize the productivity of your FANUC Wire EDM

CONTROL

Productivity- and Accuracy-Enhancing Options

OPTIONS



Rotary Axis

- For simultaneous rotary-, X-, and Y-axis cutting. Optional 5-axis CNC control is required for simultaneous rotary-, X-, Y-, U-, and V-axis cutting.

HQ Power Supply for Cutting PCD

- Optimized for cutting PCD
- Dramatically improves surface finish and accuracy with as few as 1 rough and 2 skim cuts
- Minimizes damage to PCD edges even during long-term cutting

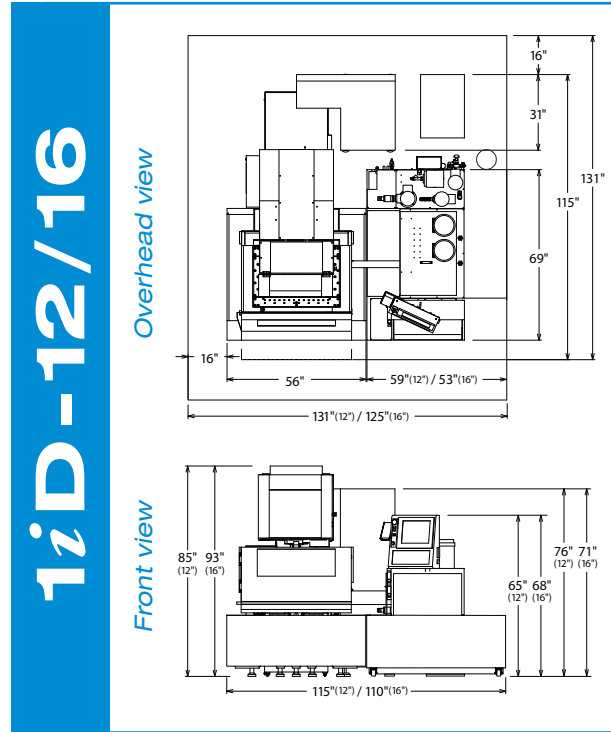
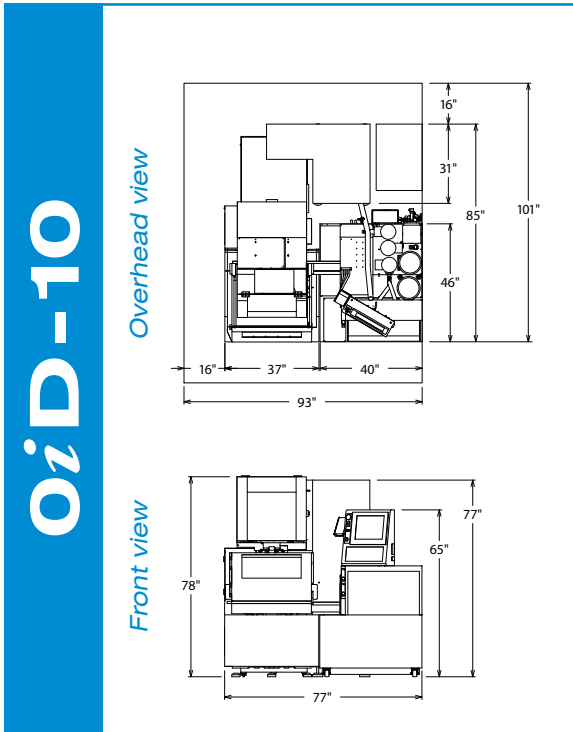

EDM Machine

		0iD-10	0iD-12	0iD-16
Maximum Workpiece Size	(Standard) inches	27.6 x 23.6 x 9.8	41.3 x 32.3 x 12.1	41.3 x 32.3 x 16.1
Maximum Workpiece Weight	pounds	1100	3550	3550
Table Travels (X & Y Axes)	inches	14.6 x 10.6	23.6 x 15.7	23.6 x 15.7
U & V Axis Travels	inches	± 2.362	± 3.937	± 3.937
Z Axis Travels	inches	10.2	12.2	16.2
Maximum Cutting Speed	(Brass wire) inches ² /hour	31.0	31.0	31.0
Table Feedrate	inches/minute	1 ~ 50	1 ~ 50	1 ~ 50
Auto Wire Feed (AWF)	—	standard	standard	standard
Wire Diameter	inches	Ø .004 - .012	Ø .004 - .012	Ø .004 - .012
Maximum Wire Spool Weight	pounds	35	35	35
Wire Feedrate	inches/minute	0 ~ 590	0 ~ 590	0 ~ 590
Wire Tension	grams	200 ~ 2500	200 ~ 2500	200 ~ 2500
Positioning Accuracy	inches	± .0001	± .0001	± .0001
Machine Weight	pounds	4000	6700	6900
FANUC 310is-WA Touchscreen Control	inches	15.2	15.2	15.2
Maximum Programming Memory	megabytes	4 MB	4 MB	4 MB
(Additional capacity available w/Flash and USB drives)				

Dielectric Tank

Tank Capacity	gallons	145	301	278
Paper Filter	(Cartridge type) quantity	2	2	2
Deionizer	(Ion exchange resin) cubic feet	1	1	1
Inverter Chiller	—	standard	standard	standard

Power Supply

Digital Power Supply	—	standard	standard	standard
AC Power Supply	(Switchable) —	AC / DC	AC / DC	AC / DC
Pulse Generator	(Transistor driven) —	standard	standard	standard
Microfinish Power Supply	—	optional	optional	optional
Input Power Supply	(3-phase, 60 Hz) VAC ± 10% KVA	200/220 13	200/220 13	200/220 13

Corporate Headquarters:

64 Union Avenue
Sudbury, MA 01776
TEL: (978) 443-5388
FAX: (978) 440-9405

Regional Technical Centers:

Charlotte	(704) 587 - 0507
Chicago	(847) 783 - 6800
Denver	(303) 216 - 1300
Detroit	(248) 624 - 8601
Los Angeles	(714) 521 - 2507
Phoenix	(602) 437 - 2220

1-877-MMT-4CNC
methodsmachine.com

