

AXYZ Series

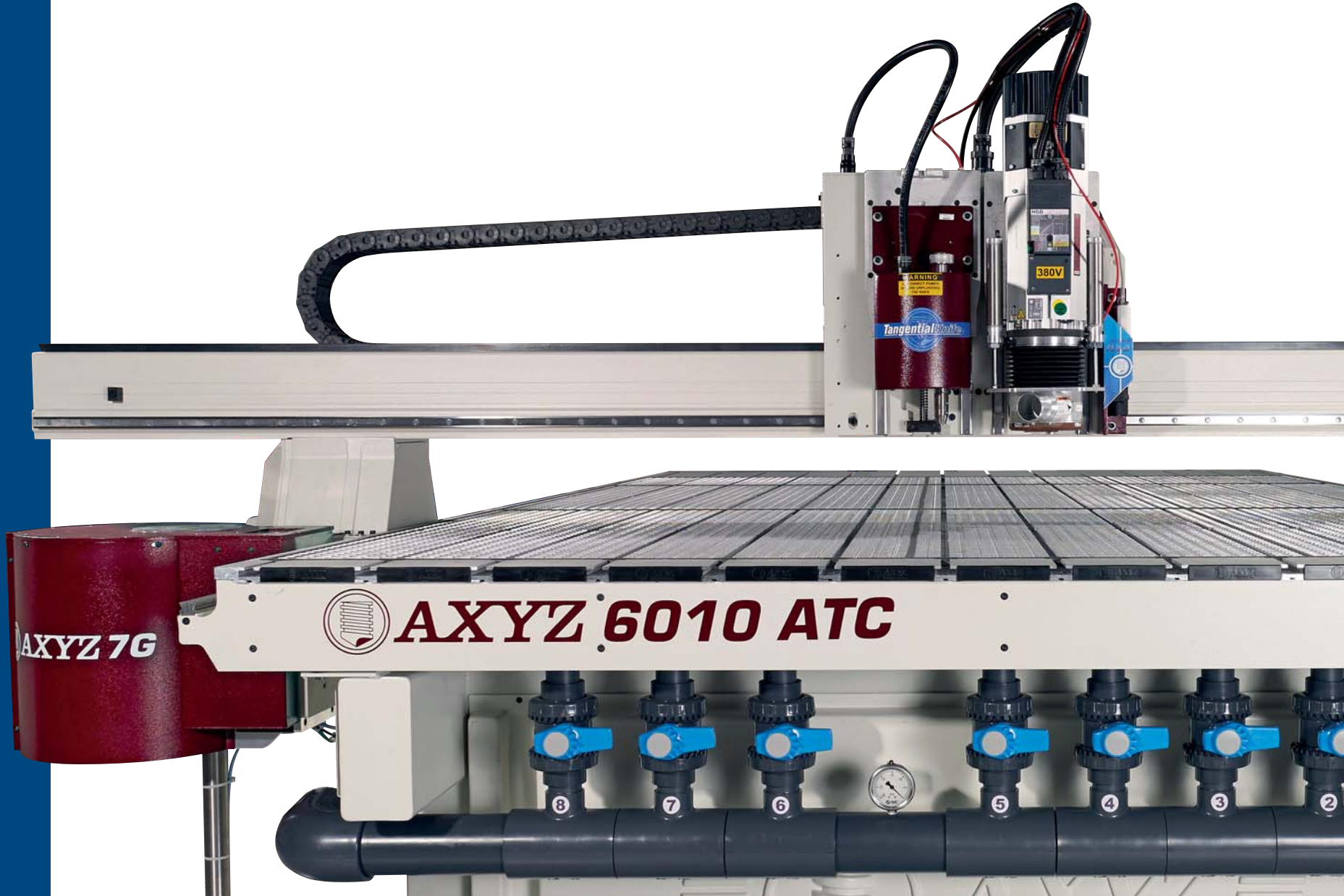

AXYZ
INTERNATIONAL





AXYZ™

The AXYZ brand offers the most diverse range of CNC routers in the industry. With more than 25 years of experience and thousands of CNC machines built and installed, you can be sure there is an AXYZ Series CNC router to meet your unique needs.

Fast

AXYZ manufacturing lead times are among the shortest in the industry. Even custom machine systems can be engineered, manufactured and delivered to meet your exacting timescales.

Flexible

The standard AXYZ Series machine can be specified in thousands of different configurations to meet almost any application requirement. Despite this flexibility there is no compromise on quality. Components are sourced from top manufacturers such as HSD and Elte (spindles), THK (bearings) and Teknic (servo motors and drives).

Direct

AXYZ interacts directly with more than 90% of our customers. With sales and support offices in Canada, the United States, the UK, Poland and India, we are near you geographically, and only a phone call or email away electronically. So, if you're purchasing a machine, require service, need engineering support or need to buy parts, you'll be dealing directly with AXYZ employees.

For the latest news, information and specifications visit: www.axyz.com

Process Areas

The AXYZ Series CNC routers are available in a wide variety of standard and custom sizes.

With process areas up to 128" wide by 49ft long and beyond, there is always a solution to suit your exact application requirements and budget.



A System Configured to Your Specific Needs

One of the greatest strengths of the AXYZ brand is the ability to configure a machine to suit almost any specific production requirement from one-off projects to high volume manufacturing.



The compact full-size machine in the AXYZ Series is the 2000. This is perfect for customers with limited workshop space or restricted access. The 2000 Series offers a processing width of 28" (711mm) and like all AXYZ Series CNC routers, its configurability enables the 2000 Series to handle the widest range of CNC tooling and application options in the industry.

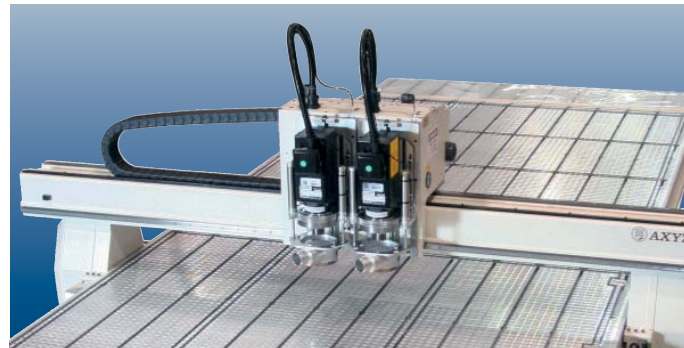

Choose a single, double or even triple-head carriage for multiple tasking operations, popular for applications that typically require only two or three tooling processes. Multi-head machines can be faster and more economical than one with an automatic toolchange system. HSD router spindles feature a simple and powerful quick-release tool change system. The manual tool-change Elte spindles provide a conventional collet and covernut alternative.



The versatility of the AXYZ oscillating and tangential knife cutting units allow an expansive range of material to be processed with ease and precision. Combine a routing spindle with an automatic toolchange and add one or more knife tools for maximum flexibility to process a massive range of rigid and semi-rigid sheet materials.

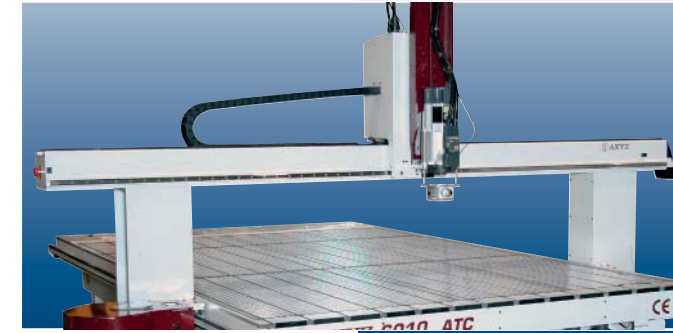

For applications that need a greater vertical clearance such as mold making or three dimensional carving, the standard 6" (150mm) gantry height can be extended to 10" (250mm), 12" (300mm) or even greater.

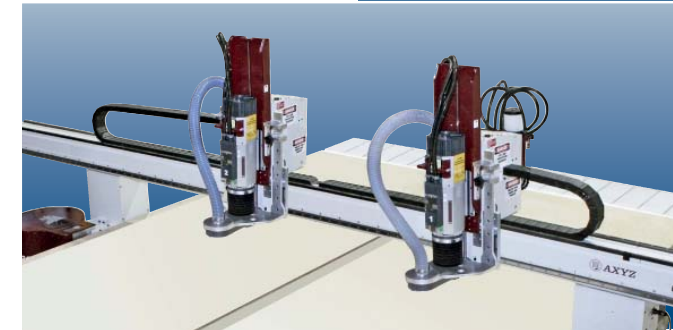

The twin carriage option enables you to copy cut two parts at the same time, effectively doubling production capacity and enabling a faster turnaround on jobs.

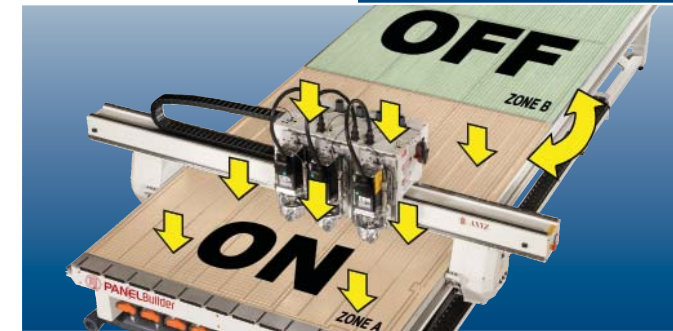

Pendulum processing allows truly continuous production by splitting the process area into two virtual zones so that a sheet can be processed on one zone while parts and waste from the other are removed.



Dual gantries on a single machine deck offer a compact and cost-efficient alternative to purchasing two router tables. The independently driven gantries allow simultaneous processing of the same or different jobs even with different tools on both ends of the table.

Features



Gantry Height

The standard 6" (150mm) gantry height can be changed to suit specific needs.

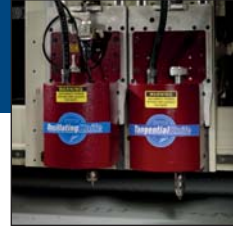

Choice of Knife Tools

Various knife tools are available to process a range of flexible and semi-rigid materials.



Router Spindle Options

Choose from manual, quick-release, high-power and high-speed spindles for optimum processing of rigid sheet materials.

Zoned Vacuum Deck

All AXYZ machines have high pressure aluminum zoned vacuum decks to maximize hold down and reduce waste.



Tool Length Sensor

An automatic tool length sensor which maintains accurate and consistent cut depths is fitted as standard on all AXYZ machines.



Customized Configuration

A wide range of tooling and head configurations are available to maximize productivity.

Pumps and Blowers

Select from a range of high-power pumps or blowers to suit machine size and application requirements.



SmartConsole

Full machine control at your fingertips for fast and easy machine setup in an intuitive and compact package.



Zone Controls

Vacuum zones can be switched with manual valves or automatically by the machine controller.

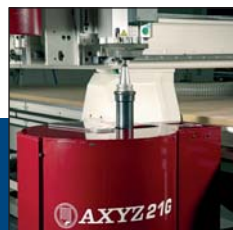

Automatic Tool Changer

The industry leading automatic toolchange systems feature a closed, protected design for safe and fast processing of complex jobs.

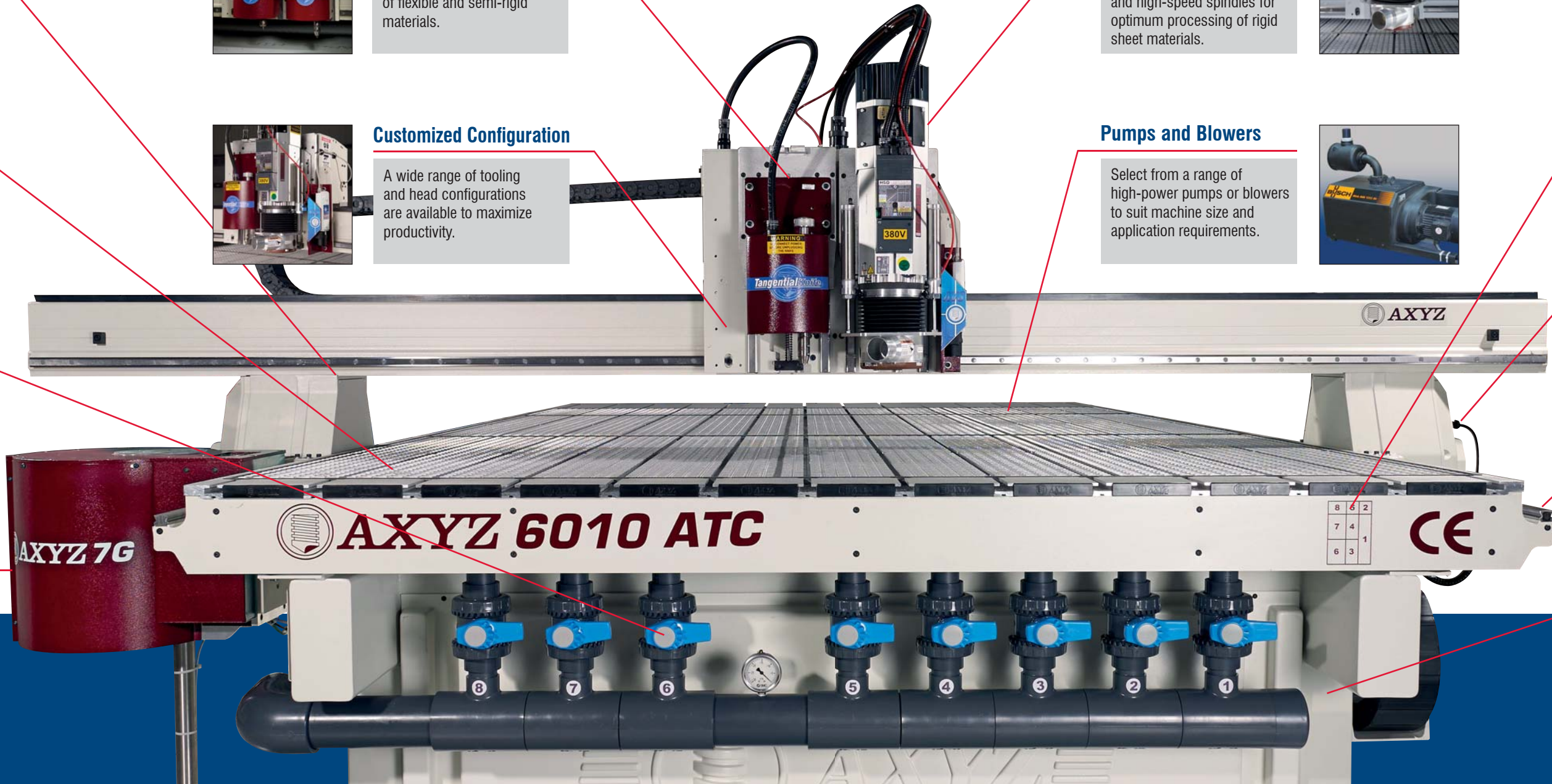

Drive System

Choose from standard or helical racks for your choice of productivity and precision. The Z axes feature precision ballscrew drives as standard.

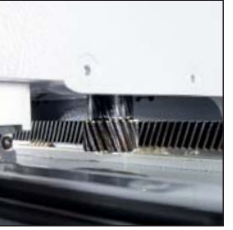

Solid Machine Base

A rigid, welded steel frame, fitted with an aluminum deck, creates a strong structure to support the most demanding processes.



XYZ 7G AXYZ 6010 ATC CE

8	6	2
7	4	
6	3	1



A2MC Machine Controller

The A2MC is a next generation machine control system and is fitted as standard on all AXYZ Series machines. With high capacity solid state storage, there is plenty of room for programs which run fast and smoothly on the dedicated motion processor. The A2MC connects the machine to your local area network for instant and error free program download.



The AXYZ SmartConsole brings unprecedented ease of use, context sensitive menus, real-time display of machine status and many more time-saving, functional and productivity features. It provides a graphical preview and current status of a running job and allows program feeds and speeds to be changed without pausing the program.

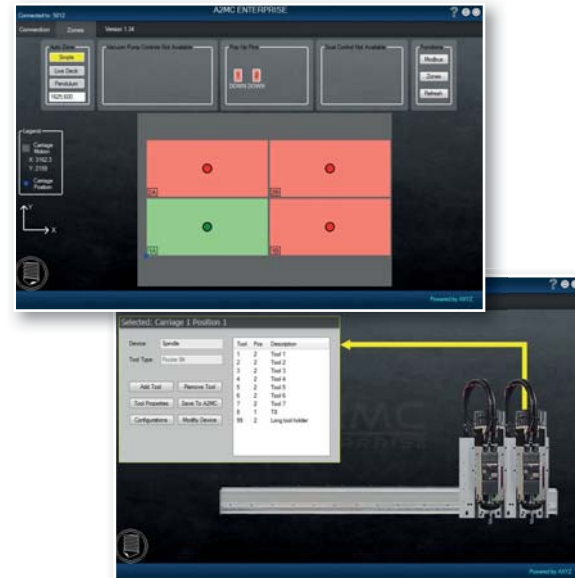

The A2MC Enterprise provides a powerful and easy to use graphical interface for setting up and monitoring your machine. Using a series of Windows-based apps it has been designed to help you get the best performance from your CNC router.



The tool length sensor is used to automatically measure the length of a tool and create an accurate tool length offset. This saves you time and ensures precise and consistent cutting depths with all tools.



The innovative design of the aluminum vacuum deck allows zoned areas to be opened or closed as needed. Flat sheet materials are held as securely as possible while cutting problems caused by movement or vibration of the materials are virtually eliminated.



The vacuum deck can be configured with either standard vacuum zones or they can be customized for your specific requirements and part sizes.

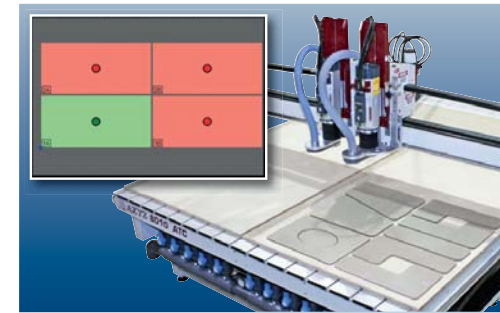

Auto zone management allows the router to operate in Live Deck mode which will automatically activate and deactivate zones according to the live position of the cutting head.

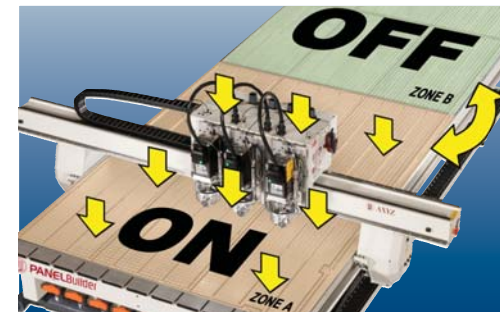

Pendulum Processing mode allows continuous production on two virtual beds. Eliminate machine downtime in between jobs to achieve up to twice the productivity.

Hold Down Options

Holding the workpiece securely is an essential requirement. AXYZ Series machines provide a choice of deck construction, zone configuration and control options.

Choose from a range of pumps and blowers to suit your applications.

Custom hold down solutions can be supplied for more challenging applications.



System Options

The option set that has been developed over more than 25 years is easily the most diverse in the industry. Through ongoing research and development, and close ties with our industry partners, vendors and customers, AXYZ offers a solution that is easily customized to suit individual requirements.

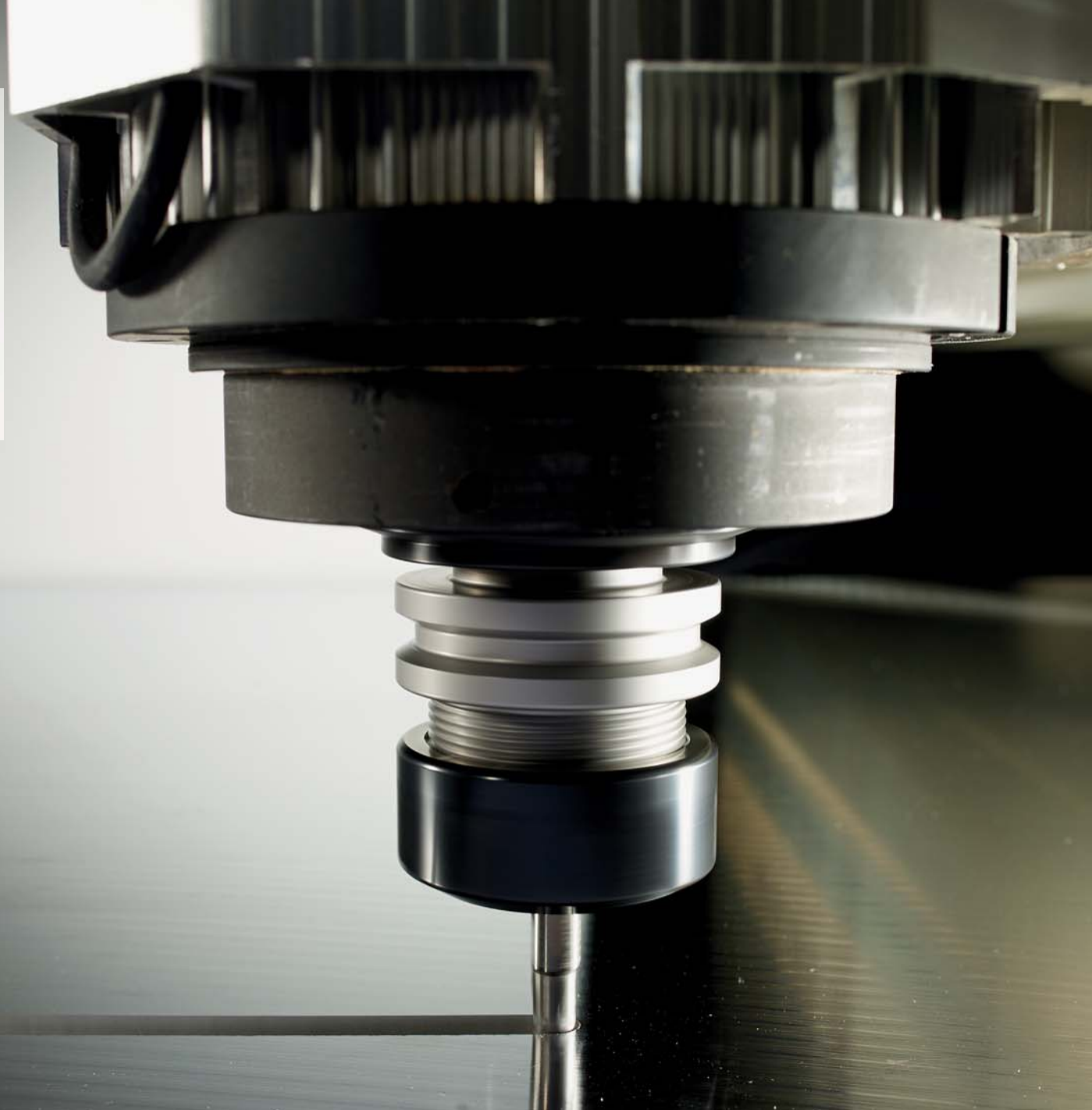

ATC - Automatic Tool Changer

Combined with an HSD quick release spindle, and using an automatic carousel with seven, 21 or 33 positions, the ATC system is the fastest method of changing tools on a regular basis.



Helical Rack

These are designed to provide superior high-speed performance and will deliver greater accuracy, smoother cutting and quieter running, making them suitable for use in all high precision and demanding applications.



Multiple Tools

Choose a single, double or even triple-head carriage for multiple tasking operations, popular for applications that typically require only two or three tooling processes. Rout, profile, trim and drill in a seamless sequence.



Multiple Carriages

To improve efficiency, multiple carriages can be mounted on one gantry to allow you to run multiple versions of the same job. Each carriage is independently driven to maintain part accuracy.



Long-Stroke Carriage

This allows you to machine thin materials with short tools but also process thicker materials with long-reach tools. A popular option for applications such as mold making and three dimensional carving.



Multiple Gantries

Multiple gantries on a single machine bed offer the user flexibility in machine use. Run different operations at either end of the machine, or park one gantry for large job processing over virtually the entire machine length.



Extended Gantry Length

Extended gantry lengths allow for full processing width when utilizing wider carriages that accommodate multiple tools. They can also be utilized for custom cutting where "off-the-table" material processing is required.



Direct-Drive Servo Motors

Delivering high speed and high torque using a precision direct-drive planetary gearhead transmission. For high-volume applications where cycle times need to be kept to a minimum, the servo drives can help boost productivity.



Extended Gantry Height

For applications that need greater vertical clearance such as mold making or 3D carving, extended gantry heights of 8" (200mm), 10" (250mm), and 12" (300mm) are available.



Heavy-Duty Steel Gantry

For situations that benefit from the greater mass of a steel gantry, our heavy-duty steel gantries are available for any AXYZ Series machine.

Configuration Options



Auto-Greasing Racks

By applying a consistent pre-measured amount of grease to the rack, the auto-greasing option keeps machine racks in optimum condition and mitigates system downtime due to failed pinions resulting from under-greasing.



High Performance Option

The auto greasing racks option is available with or without a high performance machine option. This enables the machine to run up to 2,000ipm (50m/min), to deliver shorter job cycle times and greater throughput.

Cutting Options



Vinyl Knife

Used primarily for large format vinyl cutting, cutting paper mask on acrylic sheets for painting, and for cutting paint grip with standard vinyl cutting blades and blade holder. It also doubles as a pen plotter for creating patterns.



Oscillating Knife

This is an important tool for any company that needs to process thin flexible materials including foam core, gator foam, corrugated plastic or cardboard delivering clean cut edges without fraying.



Heavy-Duty Collet Drag Knife

Designed to cut a wide variety of flexible and semi-rigid materials the heavy-duty drag knife can easily cut paper, cardboard, rubber up to 1/2" (10mm), corrugated paper and plastic.



Multi Purpose Tangential Knife

A robust knife intended for heavier, thicker and harder materials than other knives can accommodate. Full directional control of the blade allows straight edges, sharp corners and all radii to be cut cleanly and accurately.

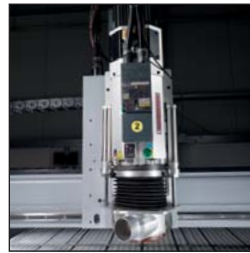

Quick Release Spindles

5 HP and 10 HP HSD quick release spindles are incredibly quiet and robust. With a simple yet powerful pneumatic quick release feature, they can be operated manually or with our ATC automatic tool changer.



Collet Spindles

The Elite line of collet spindles are precision balanced for fast, clean cutting and ultra-quiet operation. Available in 3, 5 and 10 HP models, their excellent design provides years of trouble free use.



PDS XCL70 High-Speed Spindle

A 3 HP Precision Drive Systems spindle which can operate at speeds up to 40,000rpm, allowing higher speed machining while maintaining the same high quality cut edge finish.



Plasma Cutting

Convert your router to a plasma cutter in minutes. Cut aluminum, sheet metal and stainless steel up to 1/2" (12mm) thickness at speeds over 200 ipm (5m/min) with excellent edge quality.



Pneumatic/Electric Drills

Fixture mounted tools that combine linear feed and rotation for drilling operations. Available with pneumatic feed and either pneumatic or electric rotation.



Multi-Spindle Drilling Head

A key productivity tool for cabinet makers, case good manufacturers, custom millworkers, exhibit and display manufacturers streamlining your production process dramatically.



Tangential Knife Cartridge for 45° Blades

Specially designed to hold knife blades at a 45° angle and can be used to create "V" cuts in materials such as Xanita, Reboard and others.



Tangential Knife Cartridge for Box Cutter Blades

Holds straight, multi purpose blades suitable for cutting a wide variety of materials from thin polyester film to thick card and foam board.



Tangential Knife Cartridge for Saber Blade

A robust, multi purpose tool ideal for cutting hard materials such as laminates, Styrene, Sintra and similar up to about 1-2mm thick.



Tangential Knife Cartridge for Pizza Wheel

A choice of pizza wheel cartridges are available which can accommodate 2" (50mm) or 4" (100mm) diameter rotary blades. Ideal for cutting tough or abrasive materials such as gasket, fiberglass foams and insulation.



Tangential Knife Cartridge for Creasing Wheels

Designed to fit a range of different sized and profiled creasing wheels for use in sample making applications.



Registration Options



AVS - XYZ Vision System

The AVS is a simple, low cost camera mounted on the head of the machine which when combined with a router or knife system, enables you to accurately cut out digitally printed images.



Pop-Up Location Pins

Pop-up location pins are an innovative feature which are pneumatically activated to allow fast and repeatable placement of your cutting materials onto the machine.

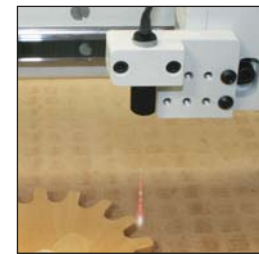

Laser Digitizer

A fast and accurate way of capturing the geometry of any two dimensional part that is placed on the table and can convert existing templates and fixtures into automated cutting files where original drawings do not exist.

Additional Options



High Capacity Pressure Foot

The high capacity pressure foot integrates with any dust extraction system for efficient debris removal resulting in faster, safer processing.

Pressure Foot Options

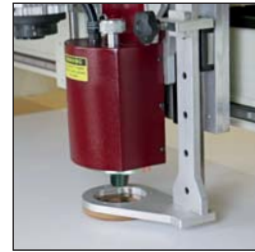

Knife Pressure Foot

Used in conjunction with the oscillating knife system, the knife pressure foot prevents soft material from lifting during the cutting process. Adding the brush donut will also avoid marking on any delicate surfaces.



Braille Insertion Tool

This tool is designed specifically for producing braille signs. It drills precise location holes for the braille beads and automatically inserts them. This is a massive timesaver for those creating braille signs to satisfy local regulations.



Nose Rider Collar

The nose rider collar sets the protrusion of the cutting tool through the bottom of the foot. Perfect for accurate grooving or slotting applications in materials which may have an inconsistent thickness.



Bellows Seal

The bellows seal significantly enhances the dust extraction process by helping to create a cyclonic vortex within the pressure foot chamber.

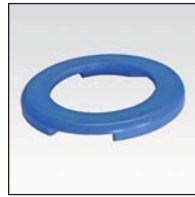

Blue Glide Donut

A unique and highly durable accessory designed for low friction. It reduces friction by up to 90% allowing smoother and faster cutting and minimizing the possibility of surface damage.



The Brush Donut

The brush donut avoids any marking of the material while at the same time providing an effective solution for the removal of dust and swarf.



Universal 5Y Pressure Foot

The 5Y pressure foot accepts 2" (50mm) or 4" (100mm) diameter hose and integrates with any dust extraction system. It allows contactless, highly efficient swarf extraction.

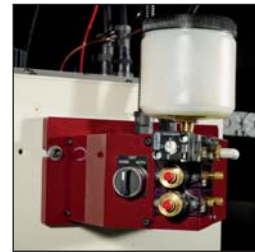

Unist Mister

For cutting non-ferrous metals including aluminum, brass and copper, the Unist mister provides a continuous output of a microfine lubricant mist, providing improved cut finish and longer tool bit life.



Vortex Cold Guns

A cost-effective option that utilizes filtered, compressed air and a Venturi effect expansion chamber to produce cold air for spot cooling, providing improved edge finish and longer tool life.



PanelPrinter

A fully integrated device designed to automatically print information onto individual parts as they are cut. Print part names, part numbers and data matrix codes.



2D Barcode Reader

Used to automate certain machine operations such as loading programs and starting the machine. It is a fast and convenient way to improve productivity and reduce the possibility of errors and wasted materials.



EZ Ryder

A purpose-built mounting plate option that reduces or eliminates glide vibration when nose riding. It does this by giving the operator the ability to reduce pressure foot loading by up to 100%.



Perimeter Switch Mats

These presence-sensing mats provide an ideal safety solution when operating your CNC router. Available in a variety of configurations they help guard the operator on one, two, three or all four sides of the machine.



Vacuum Hold Down Options



Mink Rotary Claw Pump

The Mink rotary claw pump is an ideal high-performance solution for powerful vacuum hold down. It delivers a constant vacuum and is therefore suitable for use in a variety of applications.



Regenerative Blower for Vacuum Hold Down

The 8.5 HP or 11.5 HP regenerative blower option is a low-cost solution for vacuum hold down. Best used where cut parts are at least 200 sq inches in size.



Auto Zone Management

Allows the zoned vacuum system to operate in Live Deck, Pendulum Processing or independent switching modes. Live Deck will automatically activate and deactivate zones according to the position of the cutting head.



Precision Spoil Board

Moisture resistant MDF spoil board. This is mechanically fixed to the T slot bed and acts as a sacrificial diffuser. It can be skimmed to provide a stable and flat working surface and is user replaceable.



Vacuum Manifold

An automated solution for multi head machines allowing focused debris collection at the active head, without the need to run multiple vacuum extraction lines to the table or manually open and close vacuum hose valves.



Vacuum Arm

The vacuum hose steel support arm effectively and conveniently provides a third hand in supporting the dust extraction vacuum hose. The swivelling vacuum arm allows for snag-free, full process table operation.



ACM Chip Collection System

The ACM chip collection system is a high pressure unit which is configured for the efficient collection of aluminum, aluminum composite, wood and plastic debris.